

INCLUDING  
*Communication  
Engineering*  
and  
*TV & RADIO  
ENGINEERING*

# RADIO-ELECTRONIC *Engineering*

Reg. U. S. Pat. Off.



**OCTOBER, 1954**

CITIZENS RADIO  
7

A BRIDGE FOR  
JUNCTION TRANSISTOR MEASUREMENTS  
10

A VERSATILE PULSE SHAPER  
12

NARROW BAND  
FOR MORE CLEAR CHANNELS  
14

COMPONENTS FOR PRINTED CIRCUITS  
17

R.F. MULTIPLEXING  
WITH CAVITY FILTERS  
20

NEC ANNIVERSARY  
29

## DEPARTMENTS

|                      |    |
|----------------------|----|
| COMMUNICATION REVIEW | 22 |
| NEW PRODUCTS         | 24 |
| NEW LITERATURE       | 26 |
| TV-AM-FM PRODUCTION  | 26 |
| TECHNICAL BOOKS      | 28 |
| NEWS BRIEFS          | 30 |
| NEW TUBES            | 32 |
| PERSONALS            | 36 |
| CALENDAR             | 37 |

In the final dicing operation on "rate-growth" transistor ingots at the General Electric Company plant Syracuse, N. Y., some 2000 usable bars can be diced from each ingot by means of this ganged diamond saw.

TELEVISION • ELECTRONICS • COMMUNICATIONS • AUDIO • MICROWAVES • RADAR • RESEARCH



HIGHEST FIDELITY

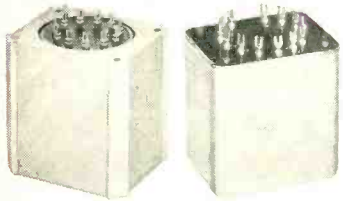

Linear Standard Hipermalloy



# TRANSFORMERS REACTORS · FILTERS

**FROM STOCK...**

COMPACT



Ouncer Plug-In

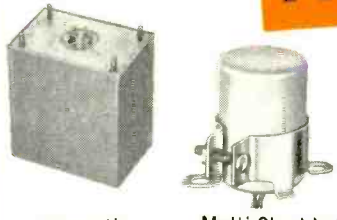

Magnetic Amplifiers Multi-Shielded Inputs

AMATEUR MINIATURE



Special Series Sub-Ouncer

HI-Q TOROIDS

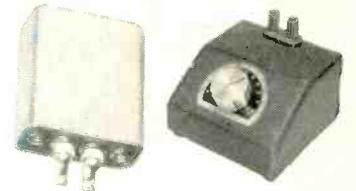

Inductors Decades

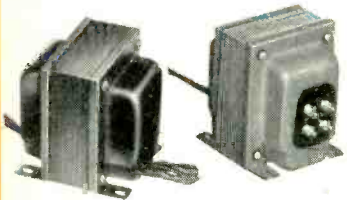

Replacement Signaling and Control

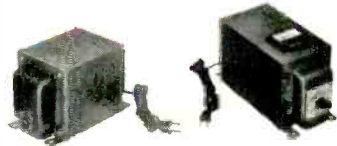

Stepdown Line Adjustors

CONTROLLED RESPONSE

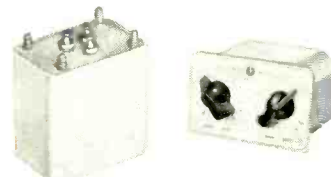

Filters Equalizers

VARIABLE INDUCTORS

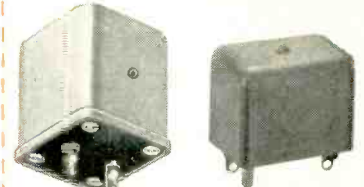

Non Hermetic Hermetic

RUGGED... INDUSTRIAL

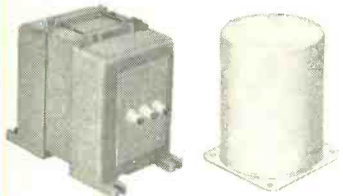
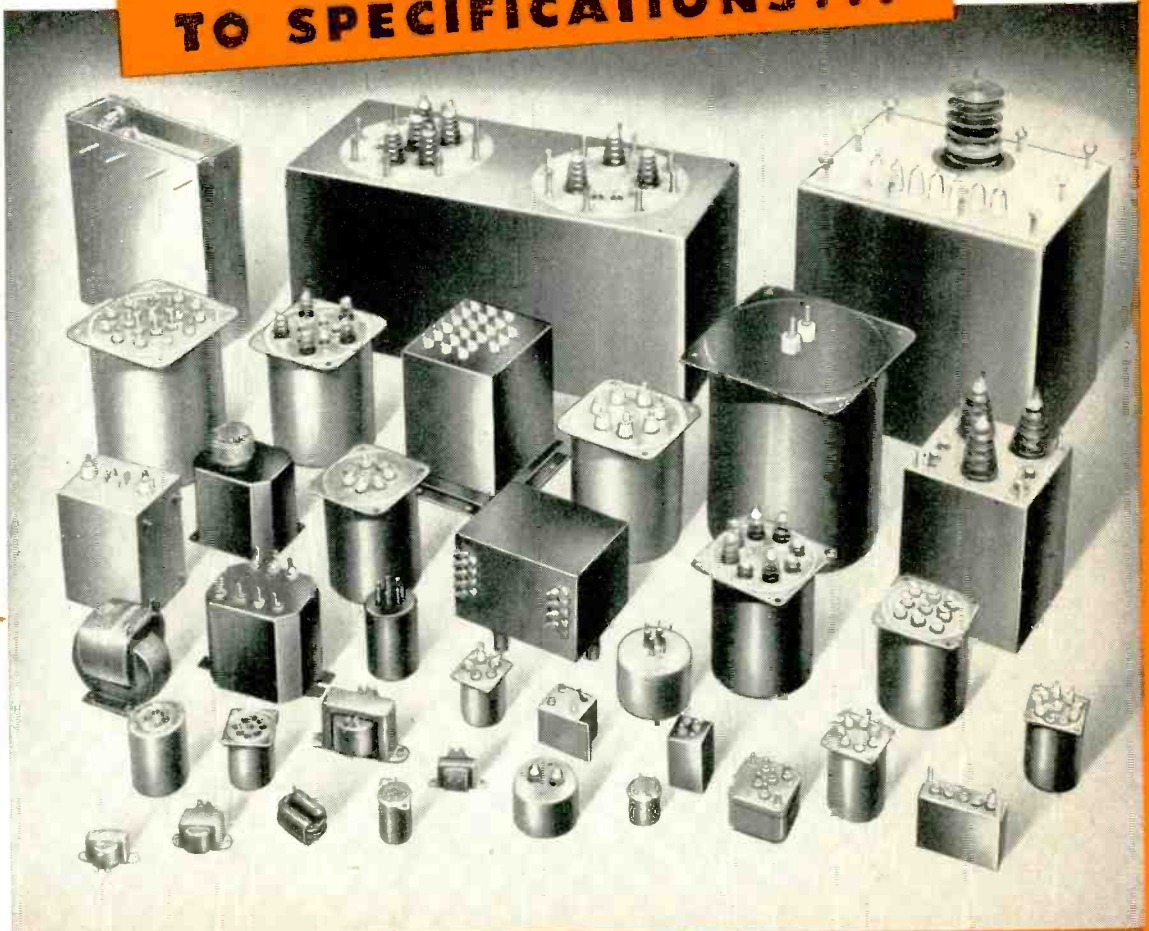

Plate Audio

**TO SPECIFICATIONS...**



HIGHEST FIDELITY



Amplifier Kit

HERMETIC... MIL-T-27



Audios Pulse Units

UNITED TRANSFORMER COMPANY • 150 VARICK STREET, NEW YORK 16, N. Y.

EXPORT DIVISION: 13 EAST 40th STREET, NEW YORK 16, N. Y. • CABLES: "ARLAB"



# ENGINEERS:

**DOES YOUR  
PRESENT JOB  
GIVE YOU**

**ALL THESE**

**RCA**

**CAREER**

**ADVANTAGES?**

**POSITIONS NOW OPEN FOR  
SENIOR DEVELOPMENT  
AND DESIGN ENGINEERS:**

- ✓ ELECTRONIC . . .
- ✓ COMMUNICATIONS . . .
- ✓ MECHANICAL . . .
- ✓ COMPUTER . . .
- ✓ ELECTRON TUBE . . .

**PERSONAL INTERVIEWS ARRANGED  
IN YOUR CITY.** A copy of our booklet  
"Challenge and Opportunity," describing the role of the  
engineer in RCA, will be mailed upon request. Please  
send a complete resume of your education and  
experience to:

MR. JOHN R. WELD  
Employment Manager, Dept. 304-J  
Radio Corporation of America  
30 Rockefeller Plaza  
New York 20, N.Y.

- CHECK SHEET**
- | Yes                      | No                       |   |
|--------------------------|--------------------------|---|
| <input type="checkbox"/> | <input type="checkbox"/> | PROFESSIONAL RECOGNITION AND PRESTIGE?  |
| <input type="checkbox"/> | <input type="checkbox"/> | ADVANCEMENT IN STATUS?  |
| <input type="checkbox"/> | <input type="checkbox"/> | SECURITY AND STABILITY?   |
| <input type="checkbox"/> | <input type="checkbox"/> | CHALLENGE AND OPPORTUNITY?  |
| <input type="checkbox"/> | <input type="checkbox"/> | HIGH SALARY SCALE AND OPPORTUNITIES<br>FOR PROMOTION?                             |
| <input type="checkbox"/> | <input type="checkbox"/> | EXCELLENT SUBURBAN HOUSING AT<br>REASONABLE COST?                                 |
| <input type="checkbox"/> | <input type="checkbox"/> | FACILITIES FOR PROFESSIONAL<br>ADVANCEMENT?                                       |
| <input type="checkbox"/> | <input type="checkbox"/> | UNEXCELLED TECHNICAL AND LABORATORY<br>FACILITIES?                                |
| <input type="checkbox"/> | <input type="checkbox"/> | ASSOCIATION WITH TOP SCIENTISTS?  |
| <input type="checkbox"/> | <input type="checkbox"/> | TUITION REFUND PLAN FOR ADVANCED STUDY?   |
| <input type="checkbox"/> | <input type="checkbox"/> | MILITARY OR COMMERCIAL OPPORTUNITY?   |
| <input type="checkbox"/> | <input type="checkbox"/> | MODERATE COST OF LIVING?  |
| <input type="checkbox"/> | <input type="checkbox"/> | MODERN RETIREMENT PLAN?   |
| <input type="checkbox"/> | <input type="checkbox"/> | COMPANY-PAID LIFE INSURANCE?  |
| <input type="checkbox"/> | <input type="checkbox"/> | COMPANY-PAID LIBERAL HOSPITAL, SURGICAL<br>AND DISABILITY PLAN (FAMILY BENEFITS)? |
| <input type="checkbox"/> | <input type="checkbox"/> | LIBERAL VACATION PLAN?  |
| <input type="checkbox"/> | <input type="checkbox"/> | LIBERAL HOLIDAY SCHEDULE?   |
| <input type="checkbox"/> | <input type="checkbox"/> | PROFESSIONAL STATUS AND UTILIZATION OF<br>YOUR EDUCATION AND EXPERIENCE?          |



**RADIO CORPORATION of AMERICA**



You'll find them all in the new



CATALOG  
of

*the World's Toughest Transformers*

These are just a few of the popular types of transformers for military, new equipment, general replacement, control and power circuit applications listed in CHICAGO's new Catalog . . . over 500 transformers, with complete physical and electrical specifications on each unit.

And more important—they are all in stock for quick delivery from your local CHICAGO distributor.

**Write Now FOR YOUR FREE COPY  
OF THIS VALUABLE REFERENCE.**

Ask for Catalog CT-554

**CHICAGO STANDARD TRANSFORMER CORP.**

3501 ADDISON STREET • CHICAGO 18, ILLINOIS



**EXPORT SALES:**  
Roburn Agencies, Inc.,  
431 Greenwich Street,  
New York 13, N. Y.

For further information, circle No. 8 on Reader Service Card

**RADIO-ELECTRONIC**  
*Engineering*

INCLUDING

*TV & RADIO* & *Communication*  
**ENGINEERING** *Engineering*

Edited by H. S. RENNE  
and the Radio & Television News Staff

VOLUME 23 NUMBER 4  
OCTOBER, 1954

Editor and Asst. Publisher  
**OLIVER READ, D. Sc., WIETI**

Managing Editor  
**WM. A. STOCKLIN, B. S.**

Technical Editor  
**H. S. RENNE, M. S.**

Assistant Editor  
**M. C. MAGNA**

Art Editor  
**FRANK SAYLES**

Draftsmen  
**ALBERT A. GANS**  
**JOSEPH A. GOLANEK**

Advertising Manager  
**L. L. OSTEN**

Midwest Adv. Manager  
**JOHN A. RONAN, JR.**

Western Adv. Manager  
**JOHN E. PAYNE**

**ZIFF-DAVIS PUBLISHING COMPANY**

WILLIAM B. ZIFF (1898-1953) FOUNDER  
Editorial and Executive Offices  
366 Madison Ave., New York 17, N. Y.

President  
**B. G. DAVIS**

Vice-Presidents  
**H. J. MORGANROTH**  
**M. H. FROELICH**

Secretary-Treasurer  
**G. E. CARNEY**

Circulation Manager  
**M. MICHAELSON**

**BRANCH OFFICES**

CHICAGO (1): 64 E. Lake St.  
LOS ANGELES (14): 900 Wilshire Blvd.

RADIO-ELECTRONIC ENGINEERING is published each month as a separate publication and is available by subscription only when purchased with a subscription to RADIO & TELEVISION NEWS.

(Average Paid Circulation Over 28,000)

Copyright 1954 by Ziff-Davis Publishing Company  
(All Rights Reserved)



...how good is

# BEST?



## BEST

... By **TEST!**  
... By **PERFORMANCE!**\*

These curves are authentic recordings taken from actual results obtained from a nationally known independent testing laboratory.

*and here's proof!*

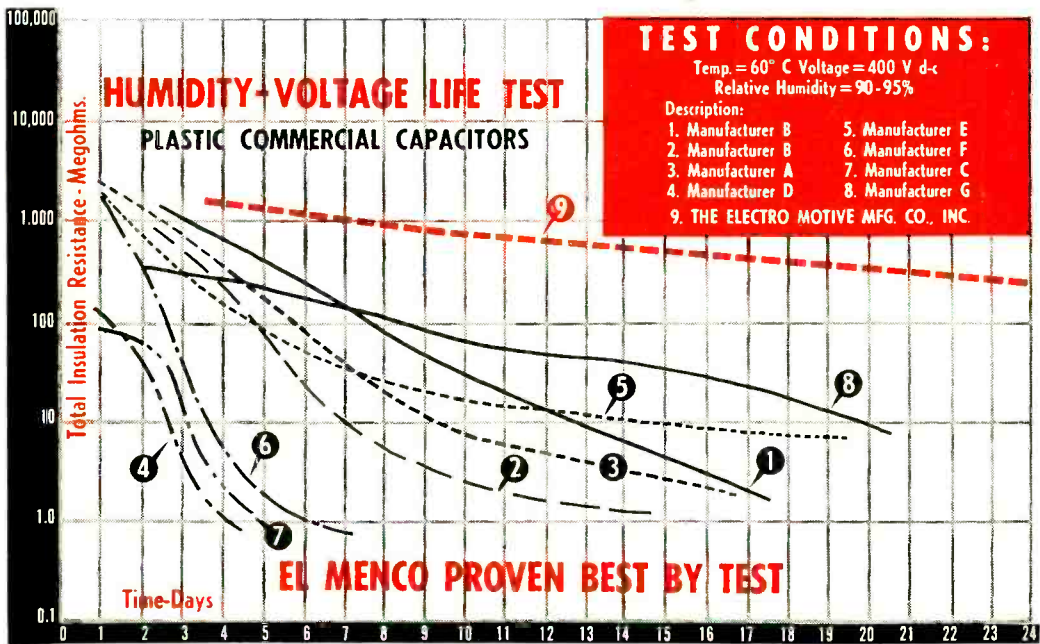

\* CERAMIC CASED PAPER DIELECTRIC CAPACITORS —

\* More than 60 million of these capacitors have been used by nationally known radio and television manufacturers with no reported field failures. These ceramic capacitors are available in 200, 400, 600 and 1000 working voltage ratings.



Write for sample and catalog on your firm's letterhead.

Jobbers and Distributors are requested to write for information to Arco Electronics, Inc., 103 Lafayette St., New York, N. Y.

# El-Menco

## CAPACITORS

MOLDED MICA

MICA TRIMMER

Foreign Electronic Manufacturers Get Information Direct from our Export Dept. at Willimantic, Conn.

THE ELECTRO MOTIVE MFG. CO., INC.

WILLIMANTIC, CONNECTICUT

For more information, circle No. 4 on Reader Service Card

# New circuit development obsoletes conventional UHF 2-Way Radio design

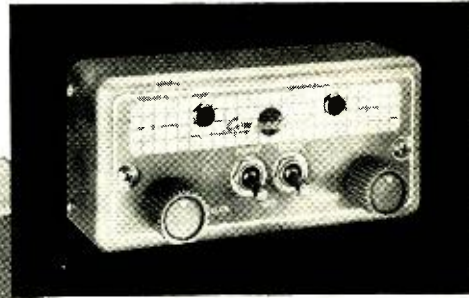
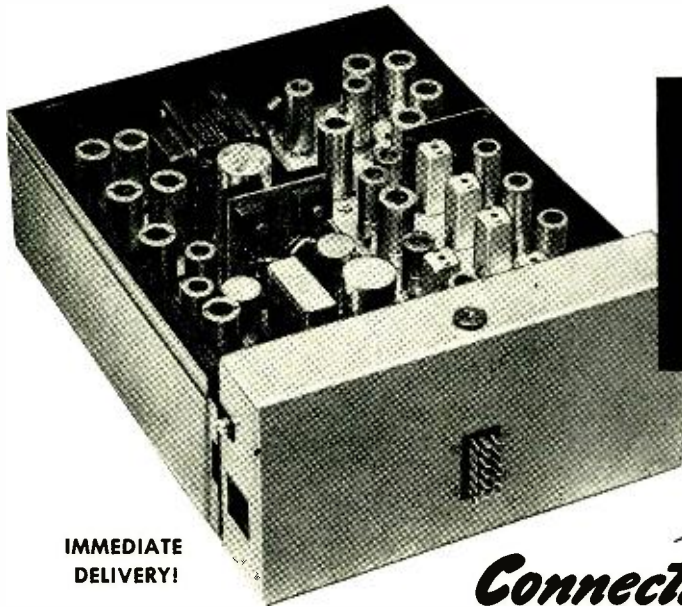

IMMEDIATE DELIVERY!

## Connecticut **FLEETWAY** FIRST FM 2-WAY RADIO

### UNIQUE CONN-TENNA DESIGN BEAMS STRONG HORIZONTAL SIGNAL

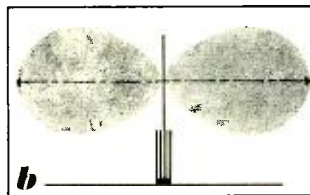
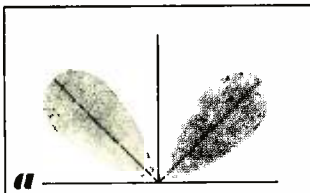

More evidence of FLEETWAY's radical design is found in its new Conn-tenna. Sketch *A* shows how conventional monopole antenna dissipates much of its signal at 45° upward angle. Sketch *B* shows how multipole Conn-tenna concentrates radiation along a horizontal plane, transmitting a stronger signal with lower power requirement.

**HIGHER OVERTONE** • The patented Lister circuit uses a starting frequency of 75 Mc instead of the usual 6 Mc. Low 6-time frequency multiplication required to reach 450 Mc contrasts with 24-times or more in other types of equipment.

**GREATER STABILITY** • Direct circuitry and fewer components permit better control of signal output, greatly minimize drift and spurious radiation. Result is greater stability requiring minimum maintenance, producing clearest signal ever attained in mobile radio.

**'FM' CLARITY MINUS NOISE** • True frequency modulation — for the first time in mobile radio — produces noise-free, natural tone quality, and eliminates distortion so common in conventional equipment. *This is true FM, not commonly used phase modulation (PM).*

**LOWER OPERATING COST** • Simplified FLEETWAY circuitry requires fewer tubes and parts — uses standard, lower cost crystals and tubes, needs less servicing.

**NEW 450-470 Mc BAND OPENS 2-WAY RADIO TO EVERY CITIZEN AND COMPANY** • Even if you have not been able to obtain a license for 2-way radio for yourself or your business, the chances are you can now get an immediate assignment in the recently opened 450-460 commercial fleet band or in the 460-470 citizens' band. These new bands offer easy licensing requirements for anyone who does not qualify in one of the older channels. You can now enjoy the advantages of FLEETWAY mobile radio for business or private use.

See your local FLEETWAY dealer or write for "Technical Comparison" booklet containing parts and performance comparison of leading mobile radio equipment.

## Connecticut

CONNECTICUT TELEPHONE & ELECTRIC CORP. 104 BRITANNIA ST. MERIDEN, CONN.

For more information, Circle No. 5 on Reader Service Card





# CITIZENS RADIO



**T**WO-WAY RADIO, the art of providing radio communication between fixed points and mobile objects (whether vehicles or people) and between vehicles and/or people, has long served many segments of the public and industrial life of the United States. At present, there are four major classes of nonbroadcast two-way radio defined and regulated as the Safety and Special Radio Services by the FCC:

1. Safety Services—Marine, Aeronautical, Police, Fire, Forestry Conservation, Highway Maintenance, Special Emergency and State Guard
2. Industrial Services—Power, Petroleum, Forest Products, Special Industrial, Low Power Industrial, Relay Press, Motion Picture, Agriculture and Radiolocation Land
3. Land Transportation Services—Railroad, Urban Transit, Intercity Bus, Taxicab, Automobile Emergency and Highway Truck
4. Special Services—Amateur, Disaster Communications, and the Citizens Radio Service

The Citizens Radio Service was established on a regular basis in 1949 for the specific purpose of providing for the use of two-way radio and for the radio remote control of devices by private citizens. Regulations pertaining to the operation of radio equipment in the Citizens Radio Service are simple and easily complied with, and are outlined in detail in FCC Part 19—Rules and Regulations Governing the Citizens Radio Service, which can be obtained from the Superintendent of Documents, Government Printing Office, Washington 25, D. C., for ten cents in coin. In brief, this radio service cannot be used for purposes contrary to law or for broadcasting to the general public, nor can it carry communications for hire.

Since existing two-way radio mobile equipment is a highly engineered precision-built industrial tool, the present cost ordinarily prohibits the average citizen from exercising his new right. However, citizens operate profit-making businesses—businesses which can be operated more efficiently through the use of radio. Therefore, this radio service is being welcomed by citizen-busi-

By

**HAROLD B. SCOTT**

Coordinator, Mobile Radio Sales  
Radio Corporation of America

and

**LEO G. SANDS**

Radio Communications Consultant

*Two-way radio service for private citizens and small businesses is provided by the Citizens Radio Service.*

nessmen whose business categories were not eligible under the old rules. Citizens Radio Service licenses can be granted to partnerships, associations, trusts and corporations, as well as to individuals.

Some of the typical industries now making use of this profit-making tool are radio and TV service organizations, oil burner and refrigeration companies, and delivery services. These industries are using mobile two-way radio in the Citizens Radio Service to lower their operating costs by increasing their service call rate even while decreasing the number of operating miles, and by spreading wage and overhead costs over more productive service and/or delivery calls. There are other attractive uses of Citizens Radio Service which will develop as the cost of the radio equipment is lowered. On the farm, it is conceivable that tractors and farmhouse can be outfitted for personal convenience and economic advantage. Summer cottages beyond the reach of telephone service, for example, can be linked by Citizens Radio to nearby

villages; and the laundry man can receive calls by radio. More and more people can and will use this new radio service to save time and money.

The 460-470 mc. band and the specific frequency of 27.255 mc. have been allocated to the Citizens Radio Service. The characteristics of the u.h.f. band (460-470 mc.) make it particularly suitable for communications. Noise is virtually absent and low power equipment will provide excellent communications over controllable ranges.

### Classes of Operation

There are three general classes of operation in the Citizens Radio Service. Class A stations may be operated on any frequency within the 460-470 mc. band with a frequency stability of 0.02% and a maximum bandwidth of 200 kc. There are three channels for class A stations: 460-462 mc. and 468-470 mc., where the maximum permissible input power is limited to 50 watts (for general communications applications); and 462-468 mc., where the maximum input power is limited to 10

Plant ambulance equipped with a Citizens Radio mobile unit. Note the short whip antenna on the roof (inside circle).

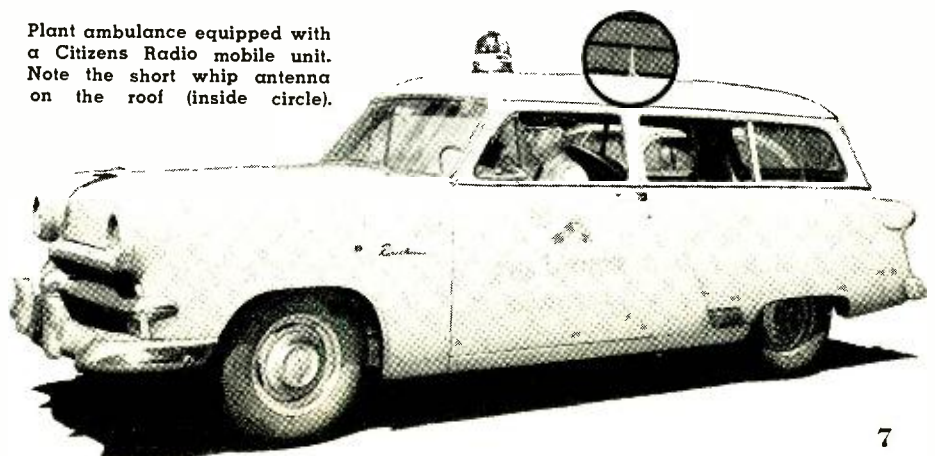

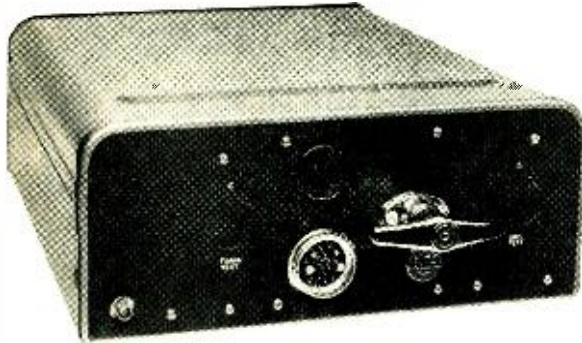
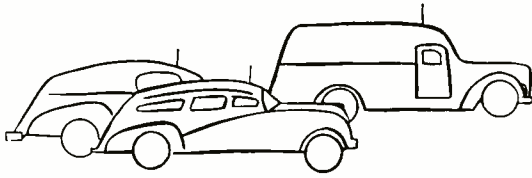

Mobile radio unit for operation in the Citizens Radio Service (RCA Type CMU-15).

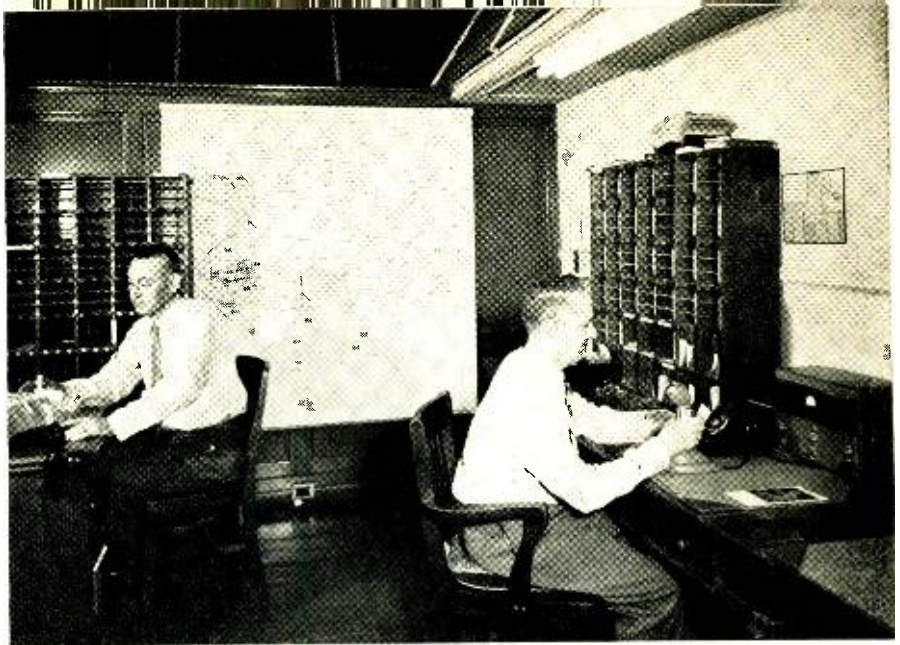

Dispatcher's office of a fuel oil delivery system. RCA Citizens Radio equipment is used to contact truck drivers in the Washington, D. C., area.

watts (for excellent short-range communications applications).

Class B stations may be operated only at 465 mc., with a maximum input power of 10 watts, and all emissions must be kept within the band limit of 462.675 to 467.325 mc. This is essentially a party-line frequency for short-distance communications.

Class C stations may be used only for radio control of objects and devices. One specific frequency is provided—27.255 mc. A frequency tolerance of 0.04% with a maximum bandwidth of 10 kc. and a maximum input power of 5 watts is permitted. This frequency, widely divergent from those frequencies allocated for class A and B usage, has proven to be of little value to the citizen-businessman as of this writing.

Under present regulations, specific frequency assignments in the 460-470 mc. portion of the Citizens Radio Service are not being made by the FCC. To permit orderly expansion, the radio industry has proposed the division of the Citizens Radio Band into specific chan-

nels. The frequency assignment plan prepared by *Radio Corporation of America* and submitted to the RETMA calls for 40 class A channels, spaced 100 kc. apart. Channels 1-20 start at 460.050 mc. and end at 461.950 mc., and channels 81-100 start at 468.950 mc. and end at 469.950 mc.

#### Ranges Covered

Quality and coverage of the higher power class A communications service in the Citizens Band can in most instances equal—and in some cases surpass—those obtained in the 152-162 mc. band mobile radio services. The propagation characteristics of 460-mc. radio signals are such that extremely solid coverage in urban areas can generally be obtained. Because of multipath propagation, the radio signals saturate areas containing narrow streets lined with tall buildings.

The range of communications in the lower power class A and the class B service with low-powered portable units is essentially limited to line-of-sight.

If line-of-sight conditions exist, the range can be several miles. Communication between two low-power portable units, both hand-carried by persons on the ground, can generally be maintained for distances up to several hundred feet or more, even when exact line-of-sight conditions do not exist. Reflections will sometimes extend the range.

Since all radio propagation at the ultrahigh frequencies of the Citizens Band is essentially line-of-sight, irregularities in the earth's surface and changes in the effective earth's profile due to seasonal vegetation must be taken into consideration when determining the maximum range of a system. The chief elements governing u.h.f. coverage are effective elevation and gain of the base station antenna. These two elements furnish the easiest and cheapest methods of providing good coverage.

Effective elevation is the height of the antenna with respect to the level of the surrounding terrain. For example, an antenna located on top of a 300' building situated in a natural bowl with sides 100' high would have an effective elevation of 200'. Naturally, base station to mobile radio unit transmission range is the same as mobile unit to base station range as long as they are of comparable power.

The other method of increasing coverage is by the use of a high gain base station antenna. As is the case with effective antenna elevation, antenna gain serves two purposes: the emitted base station transmissions are directed more forcefully, and less mobile radio signal strength is required to impress a readable signal on the base station receiver.

For higher power class A stations with an effective base station height of 350' (medium gain antenna), communications with mobile units within a

Equipment requirements for (A) mobile station and (B) base station.

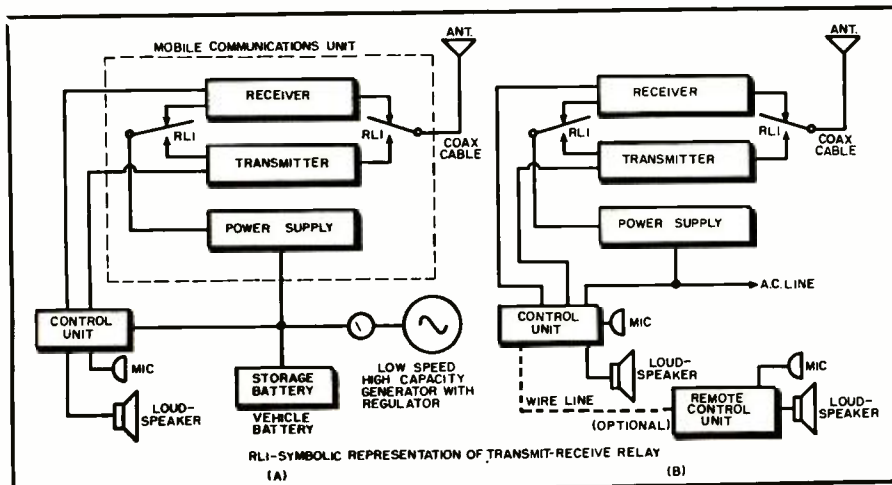



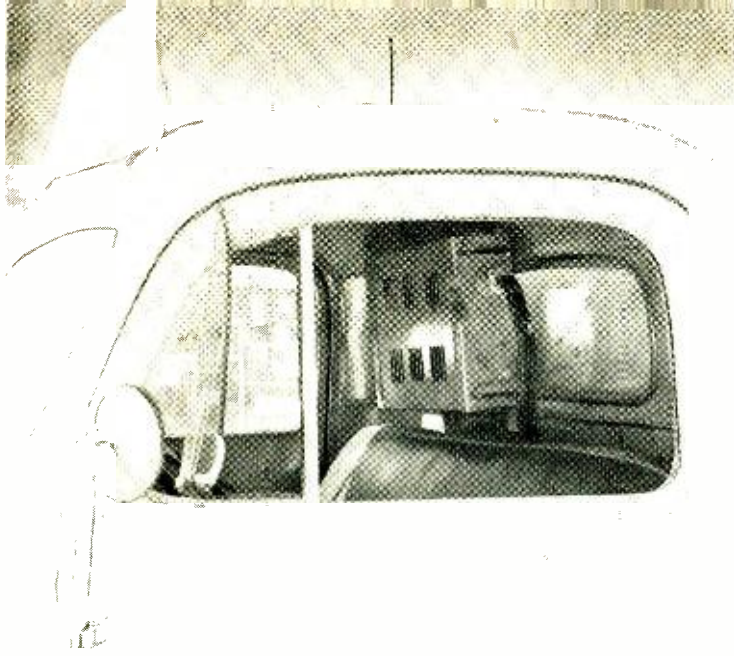

RCA Citizens Radio mobile unit installed in cab of soft drink delivery truck. Dispatcher can contact driver instantly.



Dispatcher's office employing RCA Citizens Radio for soft drink delivery. Remote control unit is on shelf above dispatcher.

radius of approximately 19 to 20 miles can generally be expected. With an effective antenna elevation of 50', the range is reduced to approximately seven miles. In urban areas, effective elevation is quite often obtained by using tall buildings for base station antenna locations.

Mobile systems employing higher powered class A base stations can be used for providing coverage of large metropolitan areas. Coverage of a large area may be accomplished by employing a single base station with a relatively high antenna system, or a multiplicity of base stations with antenna systems of medium effective height.

The vehicle-to-vehicle communicating range in class A service and class B service, under average conditions, is limited essentially to line-of-sight. However, reflections from buildings and other hard surfaces can play an important part in vehicle-to-vehicle transmission, particularly in metropolitan areas where signals actually reflect so as to give "around corner" transmission range. Another example of this phenomenon is that car-to-car communication has been maintained up to distances of 0.4 mile between two vehicles when both were inside the Lincoln Tunnel under the Hudson River. Due to the slope of the tunnel, this distance exceeded the exact line-of-sight separation of the vehicles.

For class B services, no particular systems planning problems are evident. Since communication is to be maintained on a frequency of 465 mc., which is common to all other class B station operators, and power input is limited, very few will plan to use class B service for wide coverage of a metropolitan area. A large number of stations can operate on this single frequency within a few miles of each other without seri-

ous mutual interference if antenna heights are kept low.

### Licensing

Ordinarily, except for good cause, a station license will not be granted in the Citizens Radio Service if the applicant is also eligible for a license in one of the other established radio services. The license period is for five years. No operating log is required but station identification must be announced at the beginning and the ending of each transmission, and at least once each ten minutes during prolonged transmissions.

At the present time, no fees or charges are made for Citizens Radio Service licenses, nor is an operator's license required for voice operations. Citizens' stations using manually operated telegraph transmitting by any type of Morse code require operation

**Stewart-Warner Portafone two-way unit for class B Citizens Radio Service. Unit is shown here with a.c. power supply in lieu of a battery pack.**



by an individual holding a radio-telegraph operator's license of either the Radiotelegraph Third Class Operator Permit or higher. In making application for a Citizens Radio station license, FCC Form 505 should be completed and submitted to the nearest regional FCC office or to the Federal Communications Commission, Washington 25, D. C.

Technical information on the equipment to be used, generally available from the manufacturer, must be supplied with the license application unless the equipment manufacturer has already submitted this information direct to the FCC, in which case the FCC type approval number should be entered on the license application form.

Relay stations, under some circumstances, may be licensable for extending the range of mobile-to-mobile communications, point-to-mobile communications, etc. However, inasmuch as specific frequencies are not assigned to licensees, the owner of a Citizens Band relay station may run into troubles since any radio station within range on the same frequency could inadvertently activate the relay station.

FCC rules governing the Citizens Radio Service prohibit the continuous radiation of energy for radio control of objects or devices other than model aircraft while in flight. However, no stipulation is made against the continuous radiation of energy as long as the carrier is being modulated for communications purposes.

### Equipment and Maintenance

Modern Citizens Band equipment is a precision-built industrial tool. Base stations in class A Citizens Radio Service (50-watt input) could be built to much less stringent specifications, but at present do not differ from base sta-

*(Continued on page 36)*

# A BRIDGE FOR JUNCTION TRANSISTOR

*Adaptation of a commercial vacuum tube bridge for measuring junction transistor hybrid parameters.*

THE ADAPTABILITY of the *General Radio* Type 561-D vacuum tube bridge for the simple and accurate measurement of the  $r$  parameters of point-contact transistors has been discussed<sup>1</sup>. Further study reveals that this bridge is just as readily adaptable for the simple and accurate measurement of the  $h$  or hybrid parameters of the junction transistor with only a few minor modifications. Moreover, as the  $h$  parameters are now favored by many engineers working with the junction transistor, the bridge takes on added importance.

Considering the transistor as an active four-terminal network, as shown in Fig. 1, these small a.c. signal  $h$  parameters may be defined in the following manner:

- $h_{11}$  = input impedance with the output short-circuited ( $v_c = 0$ )
- $h_{22}$  = output admittance with the input open-circuited ( $i_e = 0$ )
- $h_{12}$  = voltage feedback ratio with the input open-circuited
- $h_{21} = -\alpha =$  negative of the short circuit current gain

Over a small region of the static characteristics, the linear relations between the incremental emitter and collector voltages and currents can be described by the linear equations:

$$v_e = h_{11}i_e + h_{12}i_c \quad \dots \quad (1)$$

$$i_c = h_{21}i_e + h_{22}v_c \quad \dots \quad (2)$$

and the slopes of the appropriate set of characteristic curves are expressed by:

$$h_{11} = \left. \frac{\delta v_e}{\delta i_e} \right|_{v_c = 0} \quad \dots \quad (3)$$

$$h_{22} = \left. \frac{\delta i_c}{\delta v_c} \right|_{i_e = 0} \quad \dots \quad (4)$$

$$h_{12} = \left. \frac{\delta v_e}{\delta v_c} \right|_{i_e = 0} \quad \dots \quad (5)$$

$$h_{21} = \left. \frac{\delta i_c}{\delta i_e} \right|_{v_c = 0} \quad \dots \quad (6)$$

Thus, the hybrid parameters contain a resistance  $h_{11}$ , a conductance  $h_{22}$ , and two pure numerics,  $h_{12}$  and  $h_{21}$ . (The real components of the impedances are obtained since the small reactive components are balanced out by the bridge.) Equations (3) through (6) may be closely correlated with the dynamic coefficients of vacuum tubes,  $R_p$ ,  $\mu$  and  $G_m$ . The *General Radio* bridge measures these tube coefficients by means of null-balance arrangements of the various alternating increments<sup>2, 3</sup>. Therefore, it becomes a fairly simple task to adopt these bridge null-balance arrangements for accurate and direct measurement of junction transistor parameters.

The vacuum tube coefficients measured by the bridge are defined in Eqts. (7) through (9).

$$R_p = \left. \frac{\delta v_p}{\delta i_p} \right|_{v_g = 0} \quad \dots \quad (7)$$

$$\mu = \left. \frac{\delta v_p}{\delta v_g} \right|_{i_p = 0} \quad \dots \quad (8)$$

$$G_m = \left. \frac{\delta i_p}{\delta v_g} \right|_{v_p = 0} \quad \dots \quad (9)$$

Upon examining Eq. (7), the expression for  $R_p$ , it becomes apparent that the increments of alternating voltage and current involved correspond to those for  $h_{11}$  of the transistor. Thus,  $v_e$ ,  $i_e$ , and  $v_c$  correspond to  $v_p$ ,  $i_p$ , and  $v_g$ , respectively, if the transistor is reversed when it is inserted into the bridge so that the emitter side is inserted into the plate terminal of the bridge and the collector is inserted into the grid terminal. The simplified bridge circuit for measuring  $R_p$  and the associated circuit for measuring  $h_{11}$  are shown in Figs. 2 and 3.

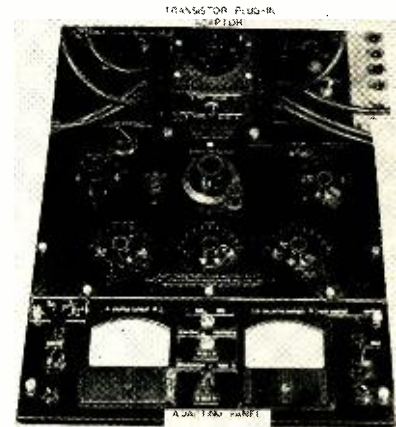

General Radio vacuum tube bridge Type 561-D adapted for transistor measurements.

The test setup for measuring  $h_{11}$  provides zero alternating voltage in the collector circuit, and the bridge  $R_p$  circuit measures alternating emitter current flowing as a result of a small voltage change introduced into the emitter circuit by  $e_1$ . Test voltage  $e_2$  is adjusted so that the resultant current flowing through  $R_g$  balances the emitter current. When the two currents are equal, a null will be exhibited by the detector and the bridge decade resistor balance will yield the value of  $h_{11}$ . Since the sharpness of the null may be obscured by reactive current which arises from transistor capacitances, lead capacitances, etc., the reactive current generator  $e_2$  (capacitance balancing winding in series with a variable capacitance) is made use of, as shown, and may be adjusted to pass an equal and opposite reactive current.

Increments of  $h_{22}$  likewise are analogous to those of  $R_p$ , that is,  $v_c$  and  $i_c$  correspond to  $v_p$  and  $i_p$ , respectively, while the condition  $i_e = 0$  may be considered the dual of  $v_e = 0$ . It is very simple to satisfy the condition  $i_e = 0$  with the insertion of a 600-henry audio

Table 1. Procedure for measuring junction transistor parameters in grounded base connection. Reference 1 gives switch details.

| BRIDGE ADJUSTMENTS       |                                    |                      |                    |                         |                             | ADAPTING PANEL ADJUSTMENTS |           |            |           |                     |
|--------------------------|------------------------------------|----------------------|--------------------|-------------------------|-----------------------------|----------------------------|-----------|------------|-----------|---------------------|
| Parameter to be Measured | Coefficient Selector Switch & Sign | "Multiply by" Switch | "Divide by" Switch | Decade Resistor Balance | Capacitor Multiplier Switch | Transistor Switch          | Switch #1 | Switch #2  | Switch #3 | Bridge Measurements |
| $h_{11}$                 | $R_p (+)$                          | 1                    | $10^2$             | adjust for balance      | out                         | test                       | reverse   | transistor | $h_{11}$  | $R_p$               |
| $h_{22}$                 | $R_p (+)$                          | 10                   | 1                  | "                       | "                           | "                          | normal    | "          | $h_{22}$  | $1/R_p$             |
| $h_{12}$                 | $\mu (-)$                          | 1                    | $10^2$             | "                       | "                           | "                          | reverse   | "          | $h_{12}$  | $\mu$               |
| $h_{21}$                 | $G_m (-)$                          | 1                    | 1                  | "                       | "                           | "                          | normal    | "          | $h_{21}$  | $G_m/10$            |



# MEASUREMENTS

By **DAVID DORMAN**

Research Laboratories  
Sylvania Electric Products Inc.

choke in the emitter circuit; this essentially opens the circuit to the bridge test signal of 1000 cps. Since  $h_{22}$  is a conductance, the value of  $h_{22}$  will be determined by the reciprocal of the resultant  $R_p$  value measured. The modified bridge circuit for measuring  $h_{22}$  is shown in Fig. 4.

The next tube coefficient to be considered is  $\mu$ , given by Eq. (8). A nearly parallel situation exists in the measurement of  $h_{12}$ , which has been defined to be a ratio of the change in emitter voltage as a result of small changes in collector voltage under the condition that there be no alternating current in the emitter (Eq. (5)). By reversing the transistor emitter and collector leads so that the bridge  $\mu$  measuring circuit is placed in the emitter circuit, the exact requirements for measuring  $h_{12}$  are met. This test setup for  $h_{12}$  provides an a.c. open circuit in the emitter when a null balance is obtained. Therefore:

$$h_{12} = \mu \text{ reading} \dots \dots (10)$$

It is very important in measuring  $h_{12}$  to throw the sign of coefficient switch to negative, as signals transmitted through the vacuum tube undergo a phase reversal while signals are transmitted through the transistor without phase changes. Thus, reversing the sign of coefficient switch is necessary to supply accurate in-phase test voltages to the transistor under test. Figure 5 shows the bridge circuit for measuring  $\mu$ , and Fig. 6 shows the modified  $\mu$  circuit designed to measure  $h_{12}$ .

When measuring the transconductance of a tube with the bridge, the alternating plate current flowing as a result of a small signal voltage introduced into the grid circuit is determined under the condition that there be no alternating voltage on the plate. A very similar situation exists in the measurement of  $h_{21}$ , which has been defined to be a measure of the alternating collector current flowing as a result of small changes in emitter current under the condition that there be no alternating voltage on the collector. Figure 7 shows the bridge circuit for measuring  $G_m$ , and Fig. 8 shows the modified  $G_m$  circuit designed to measure  $h_{21}$ . The  $G_m$  position measures:

$$\left. \frac{\delta i_c}{\delta v_e} \right|_{v_c = 0} \dots \dots (11)$$

(Continued on page 39)

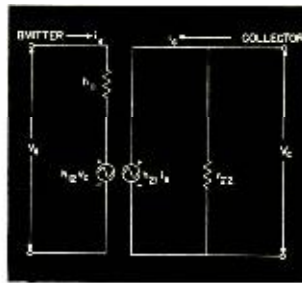

Fig. 1. Equivalent circuit of transistor shown as an active four-terminal network.

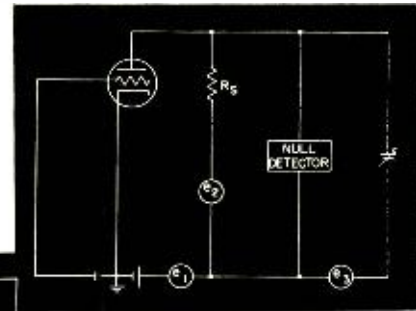

Fig. 2. Simplified bridge circuit for measuring  $R_p$  of a vacuum tube.

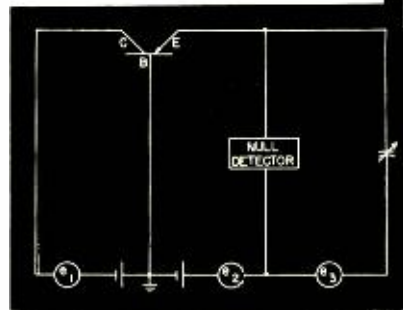

Fig. 3. Modified  $R_p$  bridge circuit designed to measure  $h_{11}$  of junction transistors.

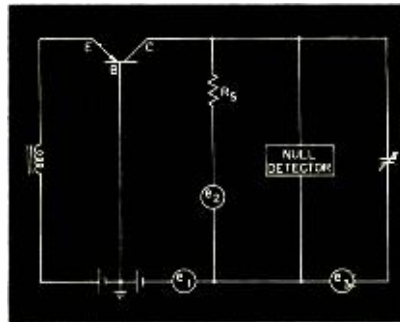

Fig. 4. Modified  $R_p$  bridge circuit designed to measure the  $h_{22}$  characteristic of junction transistors.

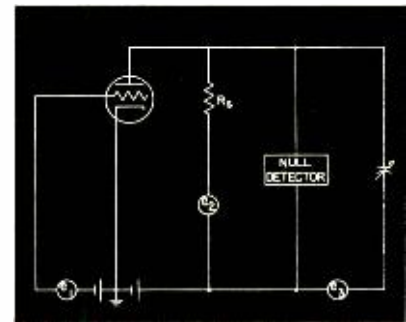

Fig. 5. Simplified vacuum tube bridge circuit for measuring amplification factor ( $\mu$ ) of a tube.

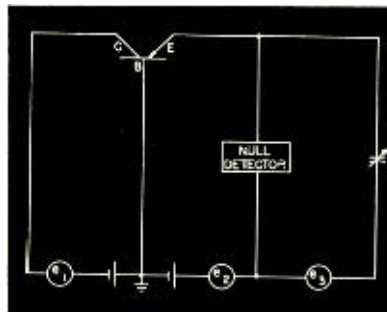

Fig. 6. Modified  $\mu$  bridge circuit for measuring the  $h_{12}$  characteristic of junction transistors.

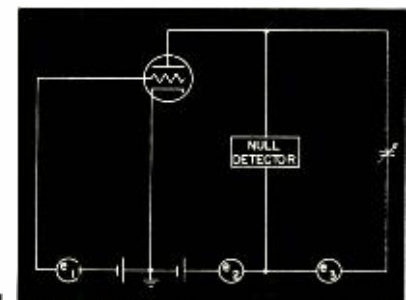

Fig. 7. Simplified vacuum tube bridge circuit for measuring the transconductance ( $G_m$ ) of a tube.

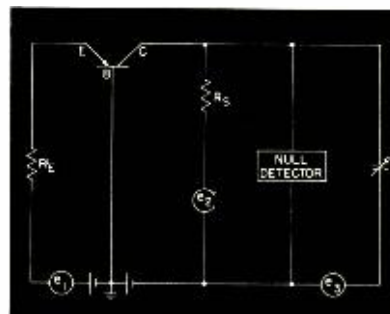

Fig. 8. Modified  $G_m$  bridge circuit for measuring the  $h_{21}$  characteristic of junction transistors.

# A VERSATILE PULSE SHAPER

By **GEORGE E. KAUFER**

Columbia University

*Thyratron circuit reforms incoming pulses, providing a train of constant-amplitude constant-width pulses.*



Assembled view of pulse shaper.

IN COMPUTERS and other pulse circuitry, it is often desirable to be able to reform sloppy pulses so that the resultant waveform will meet certain required specifications. Such reforming is particularly important where a train of high-amplitude sharp pulses is to be distributed centrally to remote parts of an installation via low-impedance coaxial lines. If the pulses originally available have variable amplitudes and widths, they must be reshaped before distribution. This article will describe the development of a circuit which can accomplish the necessary reshaping. It should be borne in mind that simplicity, reliability, compactness and economy are of prime importance in pulse shaper design, and that these factors govern the final choice of circuit.

## Problem

*Given*—a set of sloppy incoming pulses conforming to the following specifications:

1. Amplitude—between 25 and 100 volts
2. Polarity—positive
3. Rise time—less than 0.5  $\mu$ sec. (10-90%)
4. Width—from 1 to 50  $\mu$ sec. between points which are 50% of peak amplitude on the initial rise
5. Backswing—less than 25% of maximum amplitude
6. Source impedance—between 500 and 5000 ohms
7. Minimum pulse spacing—2000  $\mu$ sec. between pulses

*Find*—a simple one-tube circuit to accept these pulses and provide as an output a train of constant-amplitude and constant-width pulses conforming to the following specifications:

1. Amplitude—greater than 75 volts
2. Polarity—negative
3. Rise time—better than 0.1  $\mu$ sec.
4. Width—greater than 0.2  $\mu$ sec. between points which are 50% of peak amplitude on the initial rise
5. Backswing—less than 1 volt
6. Output impedance—low enough to drive a 100-ohm line

The terminology used in these specifications is illustrated in Fig. 1. The pulse-reshaping circuit which has been developed will not only conform to the

above specifications but can be easily modified to yield a variety of output pulse amplitudes and widths. Circuit constants are listed and resultant output waveshapes sketched.

## Circuit Development

A majority of the currently employed pulse-reshaping circuits which are to drive low impedance lines are centered about blocking oscillators. The low output-impedance requirement presents a severe limitation on the choice of an adequate circuit. After considerable thought, a blocking oscillator type generator was rejected because of the following drawbacks:

1. A blocking oscillator transformer would have to be designed and compactly constructed.
2. To eliminate backswing in the negative pulse output, the line would have to be capacitively coupled, necessitating the use of a physically large capacitor (approximately 0.05- $\mu$ fd.).
3. Eight components and a high power dual triode would be necessary, yielding only a scant maximum of approximately 75-volts output without paralleling tubes.
4. Fairly high voltage bias supplies would have to be constructed, requiring additional large components as well as special transformers. For added versatility, it is assumed that there are no negative supplies present.

Reliable triggering from the given pulses, and sharp negative output pulses greater than 75 volts in amplitude into a 100-ohm line were achieved in an experimental design using a 2D21 miniature thyratron. The cathode was grounded directly, resulting in a single high-amplitude negative-pulse output. If necessary, either output polarity could be obtained by replacing the load resistor with a pulse transformer and taking the output from one or the other terminal; however, such operation would introduce many of the disadvantages inherent in blocking oscillator units.

A variety of two-terminal pulse networks was tried, ranging from a single

0.015- $\mu$ fd. capacitor to a 10- $\mu$ hy. inductor shunted by a 1N48 diode, all in series with a 0.002- $\mu$ fd. capacitor. A tabulation of networks with relative resultant waveshapes has been formulated in Fig. 4 for purposes of comparison. It was found that a small series inductance considerably lengthened the discharge time of the capacitor, permitting one to obtain a wide range of output pulse shapes and widths. Although the opposition to changes in current afforded by the inductance appreciably lengthens the output pulse, this phenomenon is accompanied by a corresponding decrease in pulse amplitude—due to the fact that the total area under the curve represents energy and the source energy stored in the plate capacitor is fixed.

The next consideration was that of triggering with short pulses. The mechanism of initiating conduction consists of injecting on the grid a positive pulse large enough in amplitude to cause the gas between grid and cathode to ionize. If the pulse amplitude at the grid is maintained, the arc is transferred to the plate and the tube breaks down. On the other hand, if the pulse amplitude decreases appreciably, the grid-cathode arc will extinguish itself before it has transferred to the plate, and the tube will remain in the nonconducting state. It might be anticipated that as the trigger pulse width is decreased the minimum trigger amplitude required would increase. Unfortunately, when the grid-cathode circuit ionizes, the network consisting of the series grid-limiting resistor and the grid conducting resistance acts to attenuate the input trigger. This is especially serious for triggers of short duration, as the area under the pulse directly at the grid is low and hence the initial amplitude must be correspondingly high.

Since the quiescent bias voltage on the thyratron is somewhat greater than that required to prevent the tube's firing, and since for proper operation the firing of a thyratron must be posi-



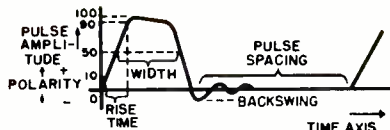

Fig. 1. Pulse waveform characteristics.

tive, it is usual to drive the grid well beyond the critical point when firing. Such a practice creates the need for a finite amount of grid power, and any circuitry feeding the grid must be capable of delivering this power. The grid current loads the driver circuit which tends to reduce the actual voltage appearing at the grid. In very high impedance circuits, the trend of this effect is to make the operation of the tube independent of the intended actuating voltage. In addition, the effect may vary; e.g., as the tube warms up, its characteristics change. Thus, the grid resistor is reduced to a minimum value so that reliable triggering may be obtained from fractional microsecond pulses. In the final circuit, 10,000 ohms was found to be a good compromise value.

The graph of Fig. 3 illustrates the aforementioned statements. A fixed grid bias of  $-4$  volts was used to obtain data for the curve, a value which was found to produce the best results. A larger negative bias would require an even greater trigger amplitude as well as introduce power supply design problems, whereas a more positive bias would result in the thyatron oscillator becoming astable.

In an effort to speed up the ionization time, pulsing and biasing of alternate grids was tried (see Fig. 7) as well as tying both grids together and triggering them simultaneously. The latter yielded the worst condition, requiring 48 volts with  $\frac{1}{2}$ - $\mu$ sec. triggers instead of 25 volts if only one grid were pulsed. Little improvement was noted by employing the complex scheme of Fig. 7 in place of simple triggering, so the idea was abandoned.

### Final Unit

The final unit is shown schematically in Fig. 6. Adequate peak current limiting is provided by the 100-ohm load. The compromise in plate pulse-forming network eventually resorted to consists of the series combination of a  $5\text{-}\mu\text{hy.}$  coil and a  $0.001\text{-}\mu\text{fd.}$  capacitor. At a pulse repetition frequency of 400 cycles, the peak output is 140 volts negative (see graph of Fig. 2) into a 100-ohm line with a pulse width (50% down) of  $0.28\ \mu\text{sec.}$  The rise time (0.1 to 0.9) is  $0.08\ \mu\text{sec.}$  and there are no oscillations. No output coupling capacitor is required.

Fitting neatly into a one-tube vector can, the thyatron sharpener meets all

(Continued on page 33)

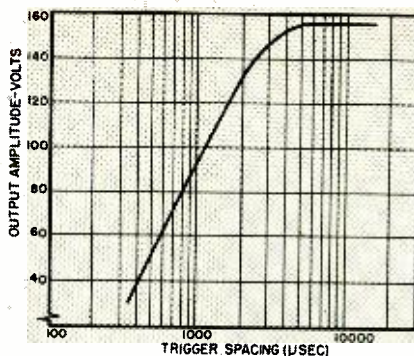

Fig. 2. Output amplitude vs. input trigger spacing for a fixed load and a  $680\text{-}\mu\text{sec.}$  plate time constant.

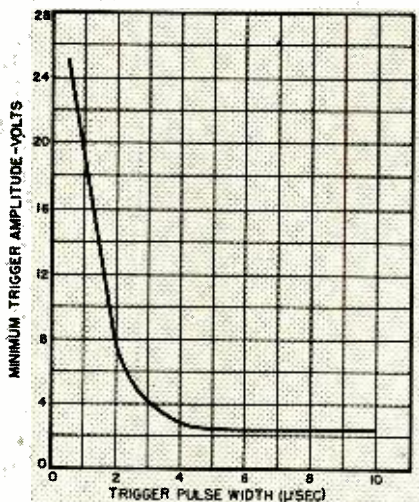

Fig. 3. Trigger amplitude vs. pulse width for fixed bias of  $-4$  volts.

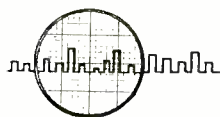

Fig. 6. Schematic diagram and parts values for thyatron pulse shaper.

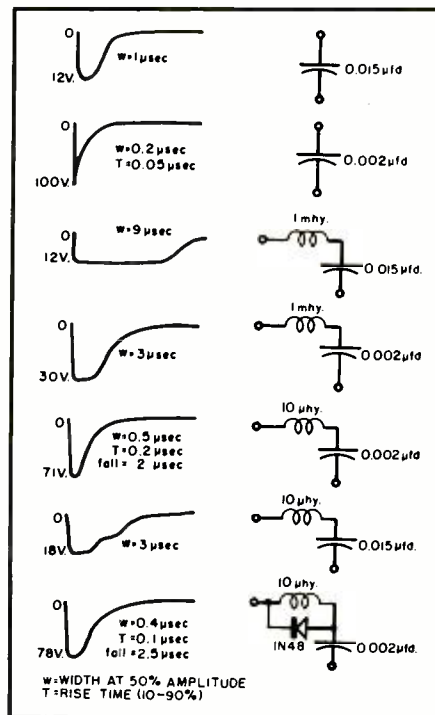
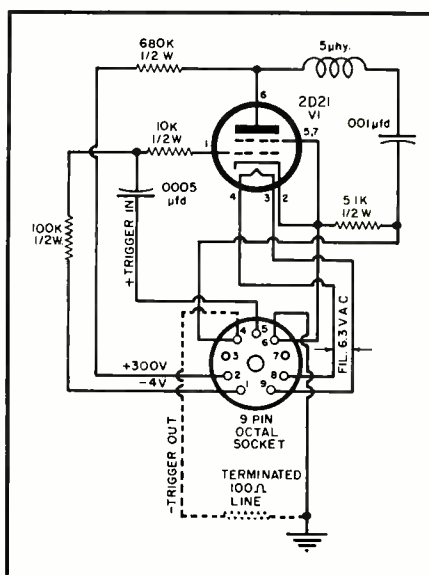

Fig. 4. Output waveshapes and plate circuit elements for basic unit.

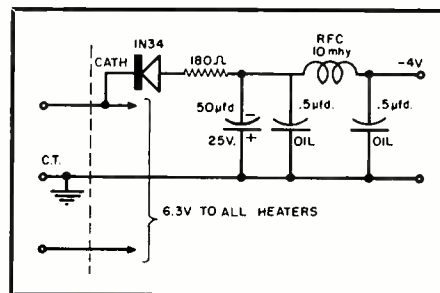

Fig. 5. Schematic diagram and parts values for a compact bias supply.

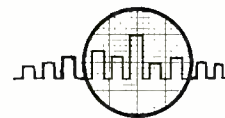
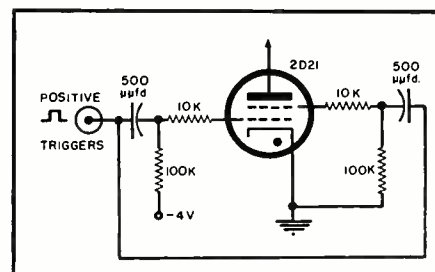

Fig. 7. Triggering circuit in which both grids are pulsed simultaneously.



# NARROW BAND FOR MORE CLEAR CHANNELS

By **J. A. McCORMICK**

Commercial Engineer, General Electric Company

*Factors involved in reducing channel width in the 25-50 and 152-174 mc. bands to improve operation.*

**C**HANNEL-SPLITTING represents a practical means of accommodating the maximum number of users in a given spectrum space. There are now a great many systems operating on a 20-kc. basis in the 25-50 mc. band and experience has shown that maintenance of narrow-band equipment is no more difficult, time-consuming or expensive than the maintenance of comparable wide-band equipment.

In the spring of 1949, the *General Electric Company* introduced a line of high-selectivity 20-kc. equipment for operation in the 25-50 mc. band, and since that time has manufactured both 20-kc. and 40-kc. equipment concurrently on the same production lines. The two types of equipment are identical in appearance, and the 40-kc. or wide-band equipment was designed for ease of conversion in the field to split-channel operation whenever a user desires—or may be required by FCC action—to make the change. Figures 1, 2, 3 and 4 illustrate the simple steps required to make this conversion. (The same technique applies to *G-E* 152-174 mc. equipment.)

Users in the petroleum radio service, because of their concentration in a limited geographic area, were among the first to feel the pinch of a limited number of channels, with the result that they have turned to narrow-band operation in fairly large numbers as a means of minimizing co-channel and adjacent channel interference. Several users have installed actual split channel systems on a developmental grant from the FCC—a sound approach on the part of any new user who is faced with the necessity of otherwise sharing the same channel with an existing system.

The case of three companies operating in Louisiana provides an example of this approach. The *Midstates Oil Corporation* and the *Transcontinental Gas Pipe Line Company* originally operated narrow-band systems but shared the same frequency, 48.74 mc., with the attendant interference to each other's operation. At 48.70 mc., only 40-kc. below, is the wide-band system of *Interstate Petroleum Communications*. In May, 1953, *Midstates* sought and obtained FCC authority to shift 20 kc. in frequency to 48.72 mc., so that the three systems are now spaced at 20-kc. intervals. These systems have since operated on that basis and no interference has been reported.

## Performance Comparison

How does the performance of narrow-band equipment compare with that of wide-band equipment? There are three

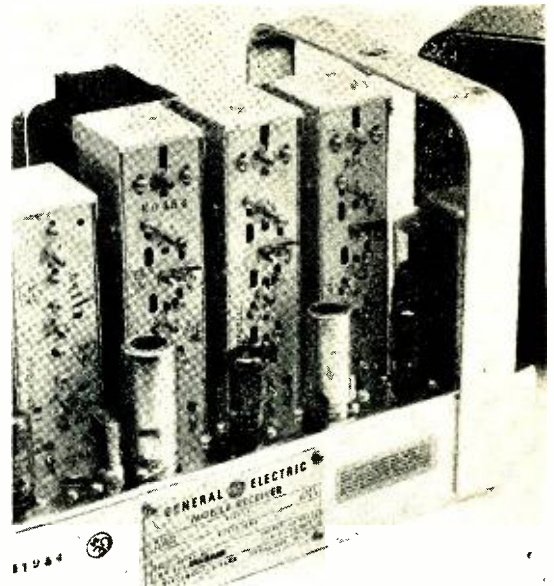

Fig. 1. In converting from wide-band to narrow-band operation, the first step is to remove the three low i.f. transformers from the receiver chassis.

experimental land stations at Syracuse geographically spaced on the points of a triangle and controlled from a central point so that controlled tests of all types can be made under practical conditions. Using these facilities, comparative 20-kc. vs. 40-kc. tests were made for representatives of the FCC in April, 1949, and have been made for many user groups since that time.

The station operator has a means of switching the peak modulation instantly from  $\pm 15$  kc. to  $\pm 6$  kc., or vice-versa, on the desired or adjacent channel transmitters. He also has a means of shifting the desired carrier frequency by any desired increment. The station wagon in which the observers ride is equipped with a narrow-band receiver and a wide-band receiver, which can be alternately switched to a common antenna and loudspeaker. A transmitter is provided for communication with the station operator.

Before leaving the vicinity of the desired station transmitter location, the squelch and volume controls of the two receivers are adjusted to the same level. They then remain untouched for the duration of the tests. Comparative tests should not be made using just a wide-band receiver, and resetting the volume control as the modulation is changed from wide-band to narrow-band, because the narrow-band reception will be penalized in signal-to-noise ratio by virtue of the fact that the wide-band receiver will admit a wider spectrum of noise due to its wider passband.

In the good signal areas, the signal-to-noise ratio of the wide-band equipment is about 3 db better than that of the narrow-band equipment. This is about the smallest difference that can be detected by the human ear and is evident only in a side-by-side comparison. In the "fringe" areas, surprisingly enough, the signal-to-noise ratio of the narrow-band equipment is actually superior to that of the wide-band equipment; therefore, it can be concluded that the ultimate range of a narrow-band system is at least equal to a wide-band system.

It has been observed that ignition noise and off-frequency operation of 1, 2 or 3 kc. have a somewhat greater degradation on narrow-band operation than on wide-band operation, but these factors are controllable and need not be decisive. The superiority of narrow-band operation shows up quite dramatically whenever an interfering signal is introduced. Whenever interference is—or is likely to be—a factor, the narrow-band system is the right answer.



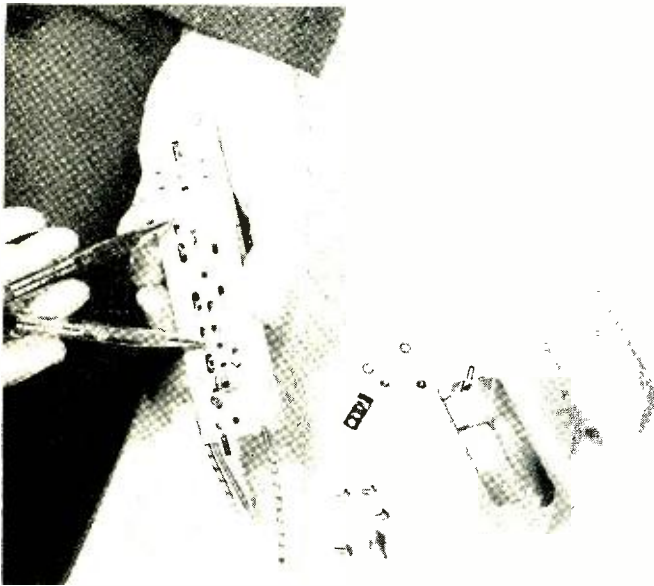

Fig. 2. The next step is to disassemble transformers and loosen mounting screws on center windings. Windings are slid to opposite ends of slots to reduce coupling.

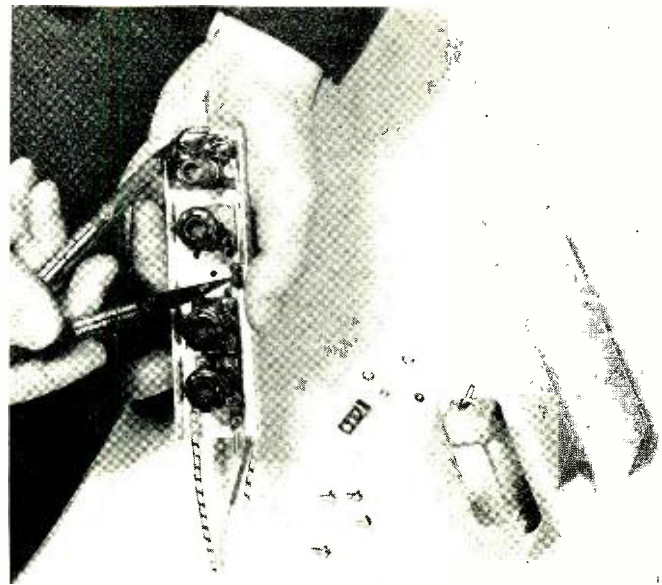

Fig. 3. Plate resistor and coupling capacitor are replaced in each transformer, and the transformers are reinstalled on the chassis deck and reconnected.

### Channel Spacing

If all of the available frequencies in a particular service are in use and a new user requests a frequency, a frequency allocation committee has no alternative but to recommend one of the frequencies already in use by another system. Obviously, it will try to "double up" those systems which have sufficient geographic separation to prevent mutual interference. But, with ever-increasing utilization of two-way radio facilities, this approach soon becomes fruitless; users within range of each other must share channels and suffer bothersome interference with each other.

Base stations in the 25-50 mc. band are usually designed for large area coverage—radii of the order of 40-50 miles. Good practice indicates that cochannel stations should be spaced from 3 to 10 times their coverage radius in order to reduce the percentage of time when the propagation path will be sufficiently good to cause mutual interference. On this basis, two stations, each with a 50-mile coverage radius, should be spaced at least 150 miles apart. By resorting to split-channel operation, from 20 to 100 db or more of protection between systems can be gained. At best, the number of clear channels can be doubled.

The criterion for channel spacing may be expressed as: "How close geographically can two base stations be operated without interference to each other?" On a shared or cochannel basis, it has been seen that a spacing of 100 to 150 miles or more is required to meet the criterion. By employing frequencies separated by only 20 kc., these distances can be reduced to 10 miles or less—a considerable improvement indeed. Still closer proximity can be permitted by choosing more widely spaced frequencies than adjacent-channel frequencies, and this should obviously be done wherever possible. The improvement is also dependent on the cooperation of the existing wide-band users on adjacent channels, who must also revert to narrow-band operation; otherwise, the isolation between systems will be no more than 20 db better than operation on the same frequency. In the event that such unfavorable conditions do prevail, however, the narrow-band user will still be about 10 db better off than his adjacent channel neighbor who remains on wide-band operation.

By use of the *G-E* range and signal strength slide rule\*, Table I has been prepared, showing the minimum separation between stations over smooth earth based on: (1) various

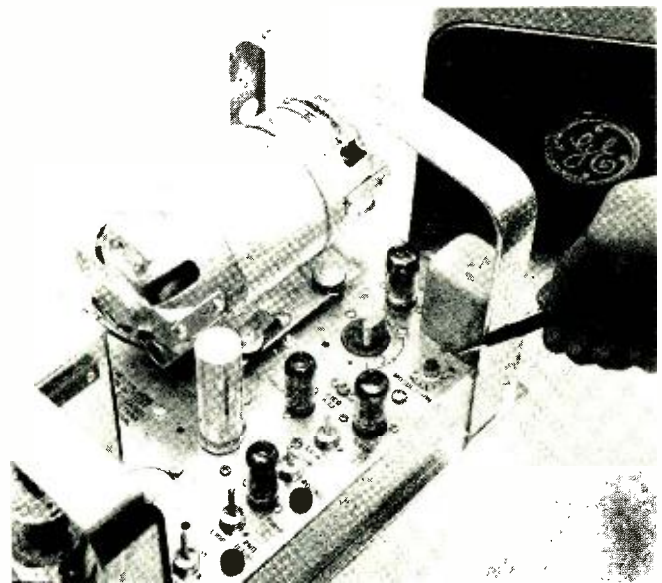

Fig. 4. Modulation control of the transmitter is set to give a peak swing of  $\pm 6$  kilocycles by means of the control knob indicated in the photograph.

transmitter powers, and (2) the degree of rejection afforded by the particular receivers (and transmitters) employed. These distances should be considered as guiding, rather than absolute, as radio propagation is subject to many variables.

At separations of less than about 10 miles, the slide rule results are pessimistic, so for the 70, 80, 90 and 100 db columns, spacings based on "free space" propagation are also shown. At these "close in" distances, "free space" is more realistic and should be used. It should also be noted that at short ranges antenna height has little effect as long as the antennas are within line-of-sight of each other.

Normally, the slide rule is used to determine the distance over which a usable signal can be delivered. In this case, it is used to learn how many miles of separation must be provided between stations so that each station receiver can re-

\*Available from *Mobile Communication Equipment Sales, General Electric Company, Electronics Park, Syracuse, N. Y.*

ject an undesired off-channel signal 60, 70, 80 or more db stronger than the desired signal. The slide rule mileages shown in the table are based on the use of a 200' tower at each station. Figures are given for both the 50-mc. and the 150-mc. band.

### Rejection Factors

There are four major factors which determine the rejection that can be obtained between two communication systems:

1. Transmitter sideband spectrum
2. Receiver i.f. selectivity, including noise width
3. Transmitter noise spectrum
4. Receiver desensitization

In adjacent channel operation, particularly in the 25-50 mc. band, the first and second factors are controlling in both narrow-band and wide-band operation. For this reason, the most important step to be taken to achieve greater spectrum utilization is to reduce the peak swing from  $\pm 15$  kc. to  $\pm 6$  kc. By so doing, each transmitter will occupy a narrower bandwidth in the spectrum and, hence, more transmitters can be accommodated.

Integrated voice modulation curves show that the transmitter sideband envelope is down only about 50 db where it crosses the edge of the channel of an adjacent channel station. Therefore, in general, to avoid sideband interference, experience indicates that one should use the 60-db column in Table 1 when deciding the permissible physical separation of adjacent channel stations in the 25-50 mc. band, or the 80-db column in the 150-mc. band.

As the frequency separation is increased beyond the spread of the sideband spectrum (that is, alternate channel and beyond), the third and fourth factors have about equal effect and become controlling. Finally, when the two frequencies are as much as 3% of the operating frequency apart, the two stations can be installed in the same building and the antennas can be mounted on the same tower without the need of cavity resonators and without interference or degradation of performance.

The ultimate limitation on the number of systems that can be concentrated in one area at the present stage of the art is imposed by that bugaboo, intermodulation spurious response (or radiation) which can be generated in both receivers and transmitters, although it is most frequently a problem in reception. Intermodulation is probably a more serious hazard in the 152-162 mc. band because of the high concentration of stations in downtown municipal areas, particularly those operated by taxicab companies, common carriers and others. In general, such concentrations are not encountered in the 25-50 mc. band, as it is good practice to locate 25-50 mc. stations in the suburban or rural areas to avoid the high ambient noise levels experienced in dense

metropolitan areas. At the same time, interference can occur over longer ranges at the lower frequencies because of the better propagation characteristics and because of the use of higher transmitter powers and mountaintop station sites.

### Interference Effects

What is the practical effect of these interference sources on reception? Transmitter sideband splatter will either be fairly understandable or will sound like "monkey chatter." Transmitter noise and receiver desensitization have very similar effects; the background noise increases when the interfering transmitter is on the air, and the signal-to-noise ratio is degraded in accordance with the severity of the interference. In its worst form, a desensitizing signal completely quiets the receiver like a strong on-frequency carrier, and completely cuts off reception on the desired frequency. Fortunately, in well-designed present-day equipment, complete desensitization only occurs within a matter of feet of an interfering station. Desensitization also shows up as a drop in second limiter grid current because it quiets "front end" noise in the receiver. A drop in limiter grid current is usually a more accurate check on desensitization than a listening test.

Another fortunate circumstance is that a strong desensitizing signal from an interfering transmitter tends to "button up" the receiver squelch; therefore, the only time interference can be heard is when a desired signal is being received also. In addition, as long as the desired on-frequency signal is as much as 6 db stronger than the interfering signal, the desired signal will "capture" the receiver and the interference will not be heard. The only time interference can then be heard is in the split-second interval when the squelch circuit is recovering at the completion of an on-channel transmission.

Intermodulation is especially objectionable because the modulation on all carriers causing it is usually heard as an unintelligible jumble, and this is further aggravated by the fact that the swing is a direct function of any carrier harmonics involved in producing the intermodulation. For example, if a third harmonic is one of the intermodulation sources, its modulation will be multiplied three times; thus, a  $\pm 15$ -kc. swing becomes a  $\pm 45$ -kc. swing. The only alleviating factor about intermodulation is that the two, three, or more transmitters causing it must be on the air simultaneously; the lack of operation of any one transmitter stops it.

### Receiver Selectivity

Susceptibility to interference due to receiver desensitization and intermodulation response can be minimized by making

*(Continued on page 35)*

Table 1. Required station spacing based on a receiver sensitivity of one-half microvolt (-143 db).

| Transmitter Power | Maximum Range      | Equipment Selectivity |                    |                    |                    |                    |                    |                    |                    |            |
|-------------------|--------------------|-----------------------|--------------------|--------------------|--------------------|--------------------|--------------------|--------------------|--------------------|------------|
|                   |                    | 60 db                 |                    |                    | 70 db              |                    | 80 db              |                    | 90 db              |            |
|                   | Slide Rule (miles) | Slide Rule (miles)    | Slide Rule (miles) | Free Space (miles) | Slide Rule (miles) | Free Space (miles) | Slide Rule (miles) | Free Space (miles) | Slide Rule (miles) | Free Space |
| 50-MC. BAND       |                    |                       |                    |                    |                    |                    |                    |                    |                    |            |
| 50 watts          | 92                 | 11                    | 6.5                | 7.5                | 3.7                | 2.4                | 2                  | 0.8                | 1.2                | .25 mile   |
| 250 "             | 107                | 16                    | 9.5                | —                  | 5.3                | 5.5                | 3                  | 1.7                | 1.7                | .50 "      |
| 3 kw.             | 127                | 27                    | 17                 | —                  | 9.7                | —                  | 5.9                | 6                  | 3.2                | 1.9 "      |
| 150-MC. BAND      |                    |                       |                    |                    |                    |                    |                    |                    |                    |            |
| 50 watts          | 70                 | 10.5                  | 6.3                | 2.5                | 3.7                | 0.8                | 2                  | .26                | 1.2                | 350 feet   |
| 250 "             | 78                 | 15                    | 9                  | 5.5                | 5.2                | 1.75               | 3                  | .55                | 1.7                | 800 "      |



# COMPONENTS FOR PRINTED CIRCUITS

By **JOHN F. X. MANNIX** and **SHERMAN G. BASSLER**

Squier Signal Laboratory

*Acceptance of the Auto-Assembly technique of circuit assembly has resulted in new component designs to fit this technique.*

**T**HE Auto-Assembly system of circuit fabrication has received widespread acceptance throughout industry since its inception by the Signal Corps prior to 1949. This reception by industry confirms the soundness of the basic concept, namely, reliable components united to prefabricated circuitry by a mass assembly operation.

Process steps for the system include: (1) preparing an insulating card with prefabricated conductors having perforated terminations to receive the component leads, (2) component mounting by insertion of the component leads through the perforations, and (3) solder-fluxing followed by solder-dipping and the removal of excess leads when necessary. The application of a protective coating to the circuitry, encapsulation, or other types of packaging may follow, depending upon service requirements. A five-tube clock radio fabricated by this method is illustrated in Fig. 1.

Many types of conventional components are directly applicable to the system as evidenced by current commercial and military applications utilizing these components. Other conventional components require only slight modification to achieve complete compatibility. Manufacturers are now providing resistors, capacitors, coils, i.f. transformers, etc., with modified leads that greatly improve their applicability to this mass assembly technique. Component assemblies such as "printed" RC networks manufactured by several commercial suppliers are also directly applicable to prefabricated circuitry.

Reactive components formed of prefabricated circuitry are practical where the operating frequency and the required values do not result in a component area incompatible with the degree of over-all miniaturization desired. Such a component is illustrated in Fig. 2, which shows a 40-mc. i.f. transformer for TV applications. The electrical characteristics of the base material are important in the design

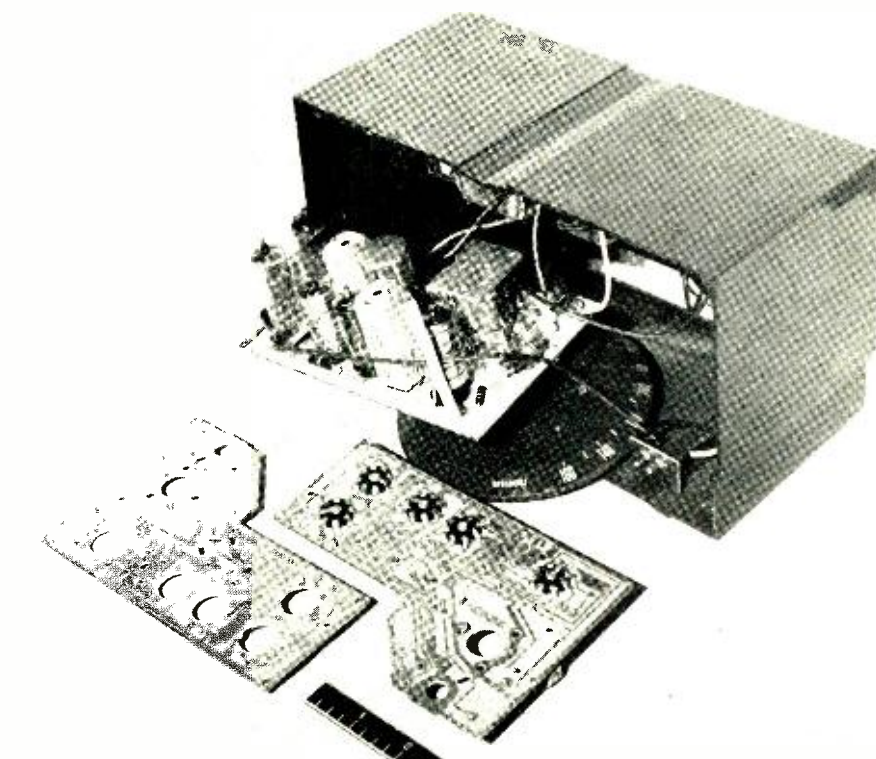

Fig. 1. A clock radio made by Hallicrafters utilizing the Auto-Assembly technique. Lower left: printed circuit phenolic chassis; lower right: chassis with sockets added.

of these components. Inductors formed of monoplane prefabricated circuitry usually are designed in a spiral, square or rectangular configuration. Similarly, capacitors of low values may be formed by interleaved conductor lines or by conductive areas on opposing sides of the base material which serves as the dielectric.

It should be pointed out that the majority of the components covered in the following discussion are items developed primarily for commercial applications. In light of this fact, some of the components may not meet all of the requirements for reliable operation under the severe operating conditions encountered by military field equipment.

Assembly of equipment using prefabricated circuitry has been greatly facilitated by the recent development of components such as resistors having mounting leads of proper length and special configurations. A swaged flat section on the leads or a slight bend serves to retain the component on the base after insertion of its leads in the terminal perforations (see Fig. 3). The snap-in action and the self-retention feature achieved by this design are

definite advantages; the self-retention feature insures proper positioning of the component during the dip-soldering operation and eliminates the need for any component holding device. Other advantages include saving in metal (no excess lead length) and elimination of the lead trimming operation. A similar snap-in design has been used for the leads and terminal tabs of i.f. transformers, r.f. coils, and slide switches, as illustrated in Fig. 5.

Components requiring additional mechanical support may have accessory parts designed to incorporate the same snap-in features. Such a case is shown in Fig. 5 (right), where the vertical mounting of two adjacent resistors is effected by means of a spring action snap-in yoke. This assembly is being used in a home radio receiver manufactured by the *Philco Corporation*.

Shown in Fig. 6 is a rotary switch employing printed circuitry to form the contacts on the stator; there are several switches of this type commercially available. A switch may also be directly integrated with the printed circuit chassis. Such a switch has the stator segments formed simultaneously with

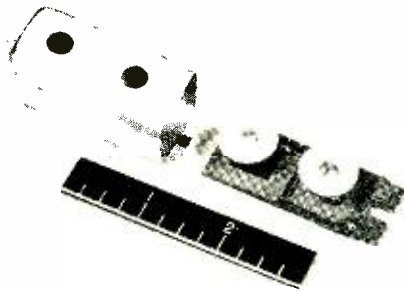

Fig. 2. RCA 40-mc. TV i.f. transformer formed by etched foil technique.

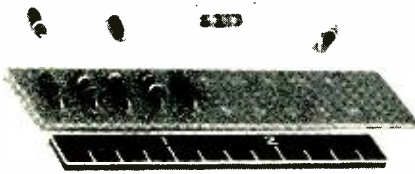

Fig. 3. IRC resistors with leads designed for printed circuit applications shown mounted and unmounted.

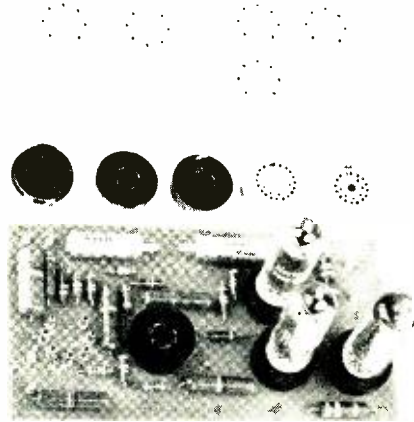

Fig. 4. Experimental five-tube a.c.-d.c. amplifier made with printed circuit technique, miniature tube socket adapters, and Auto-Semby system of fabrication.

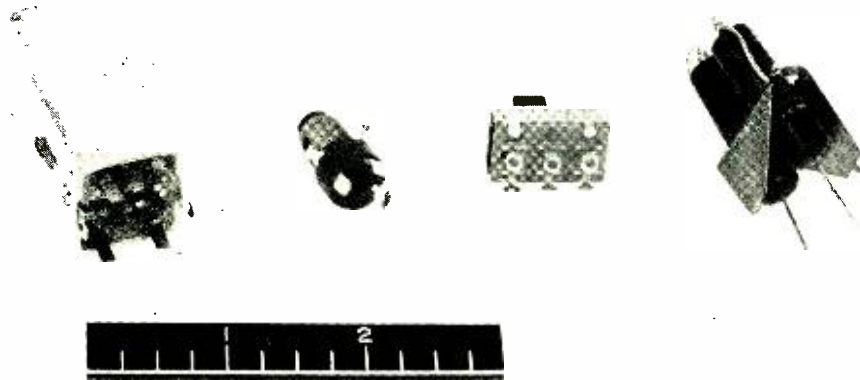
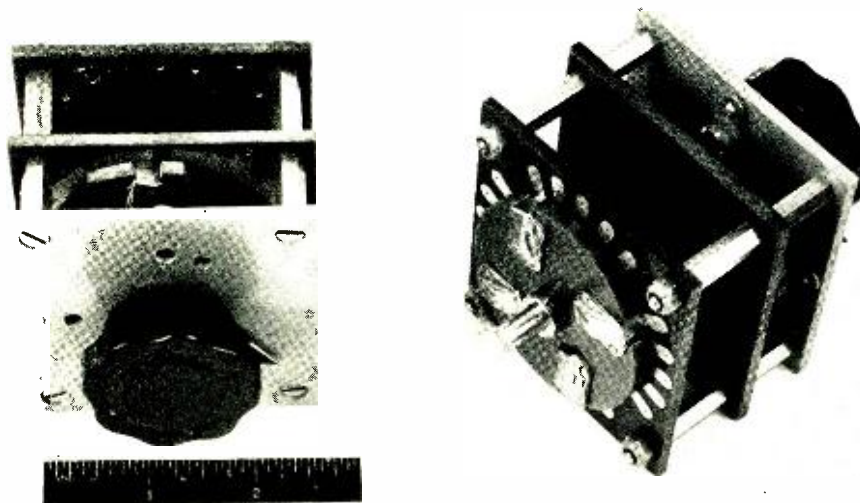

Fig. 5. Commercial items suitable for Auto-Semby system of circuit fabrication: (left to right) i.f. transformer, oscillator coil, slide switch, and resistors.

Fig. 6. Two views of a rotary switch with a printed circuit stator. This switch is manufactured for commercial applications by the Daven Company.



the circuit conductors; the rotor, shaft detent mechanism and printed circuit stator are assembled on the chassis or card. The multimeter switching circuit illustrated in Fig. 7 provides an example of this principle; it was developed by Coles Signal Laboratory and is presently being used in a military test instrument.

Components for the Auto-Semby system should have stiff, fixed, protruding terminations to permit manual or automatic insertion of the component leads into the appropriate perforations in a printed circuit board. It is an accepted concept that socket contacts require "float" (movement within the cavity walls of the socket) to accept the tolerances found on the pin circles and pin diameters of tubes and other plug-in type components. The soldering tabs found on conventional sockets therefore have a certain freedom of motion, and this freedom makes it difficult to insert the tabs into the mounting holes in the circuit board. Excessive tolerance in circuit-board hole diameters is required to accommodate the soldering tabs unless a careful manual adjustment is performed on each tab. Dip-soldering of the tabs in the oversize perforations is also difficult unless the tabs are bent over onto the terminal areas. As the transmission to the printed circuitry of tube insertion forces is undesirable, such forces should be eliminated as much as possible in the design of sockets for printed circuit applications.

A five-tube experimental amplifier with adapter-type sockets is shown in Fig. 4. The adapter socket is one of the first approaches to the socketing of electron tubes and other plug-in type components in the Auto-Semby system. In this method, adapter pins are staked into the phenolic chassis and solder-dipped to form a good electrical connection to the circuit conductors, and the phenolic adapter body is then pressure-fitted over these pins. The insulator body contains double-action beryllium copper springs; one side of a spring makes a firm contact with the adapter pins while the other side receives the pins of the units being inserted into the adapter. This type of adapter has been used in some commercial and military equipment to retain the

Fig. 7. Experimental etched foil multimeter circuit developed by the Coles Signal Laboratory.

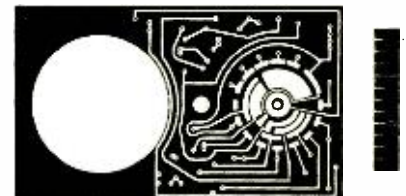



7- and 9-pin miniature and octal electron tubes as well as 14- and 20-pin relays. Electrical performance of an adapter-type socket (properties of the contacts, the insulation resistance and the breakdown voltage between contacts) compares favorably with regular tube socket performance. As the adapter contacts have little "float," care must be exercised when inserting miniature tubes into the socket to assure that the delicate glass headers are not damaged. Since the adapter is held firmly to the chassis by the action of its springs against the adapter pins, no additional means of mounting is required. Extra assembly time is required when using this type of adapter since each contact pin must be riveted to the chassis.

Three other types of sockets that have been used with printed circuitry are shown in Fig. 8, all of which have rigid contacts with no "float." At the right is a type of "snap-in" socket which has its contacts placed inside a molded phenolic body and held in place by a disc riveted to the top of the socket. Contact tabs protrude from the top and are bent down along the sides of the body. The socket is pressed into the chassis hole from the top; phenolic ledges between the contacts keep the top of the socket above the chassis, and the spring action of the tabs holds the socket in place. Past experience has shown that sockets having a laminated construction are prone to trap moisture when subjected to the severe humidity conditions encountered in military service. Commercial applications do not impose this stringent requirement upon tube sockets.

Next to this socket in Fig. 8 is another "snap-in" type (a second manufacturer's version is shown in Fig. 9). This type of socket is an adaptation of the standard miniature tube socket employing the conventional socket insulator body with a standard-type contact lengthened and shaped to fit back over the sides. It is pressed into place with the contact tabs serving as snap springs to retain the socket in a card; no other means of mounting is necessary. Satisfactory results have been obtained with this type of socket in a number of commercial applications. It is available with both general-purpose and low-loss phenolic insulator bodies in both the

(Continued on page 34)

Fig. 8. Sockets for printed circuit applications made by Cinch Mfg. Corp.

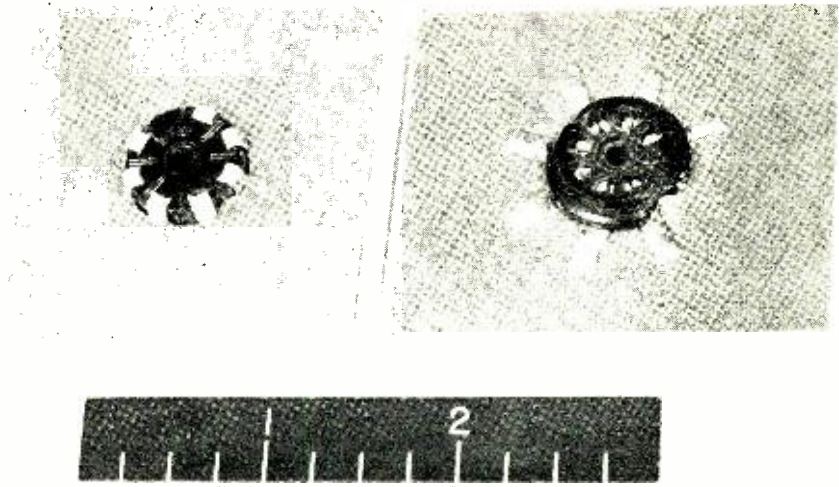
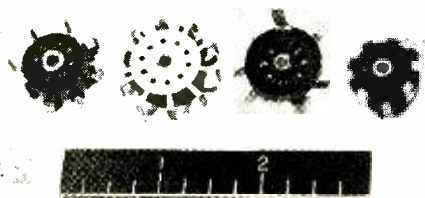

Fig. 9. Printed circuit miniature tube socket manufactured by Methode Mfg. Corp.

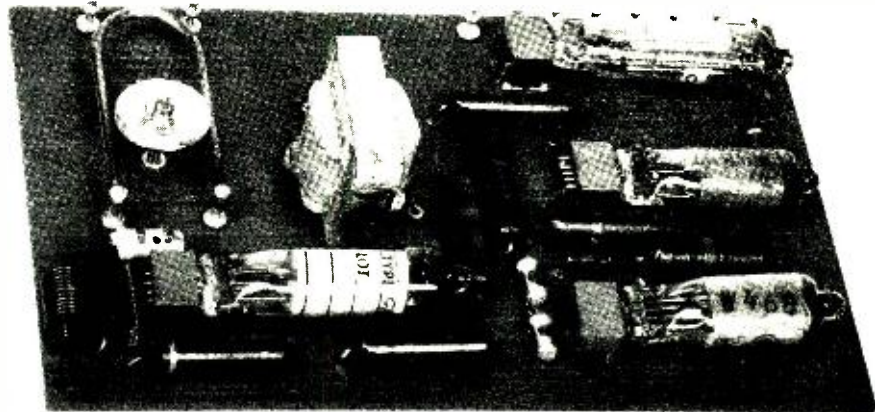

Fig. 10. An experimental superregenerative receiver with printed circuit subminiature sockets. The Auto-Semby technique was used for circuit fabrication.

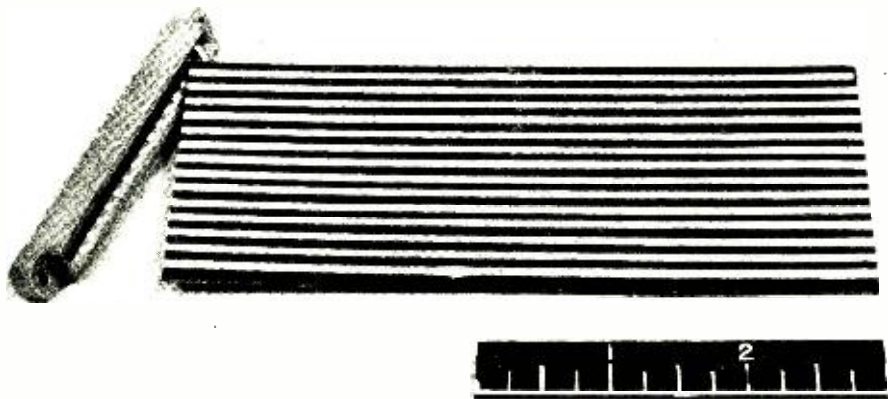

Fig. 11. Receptacle for printed circuit card, made by Winchester Electronics, Inc.

Fig. 12. Over-all view shows five types of card receptacles designed for printed circuit applications. Center: printed circuit card and receptacle in mated position.



# R.F. MULTIPLEXING WITH CAVITY FILTERS\*

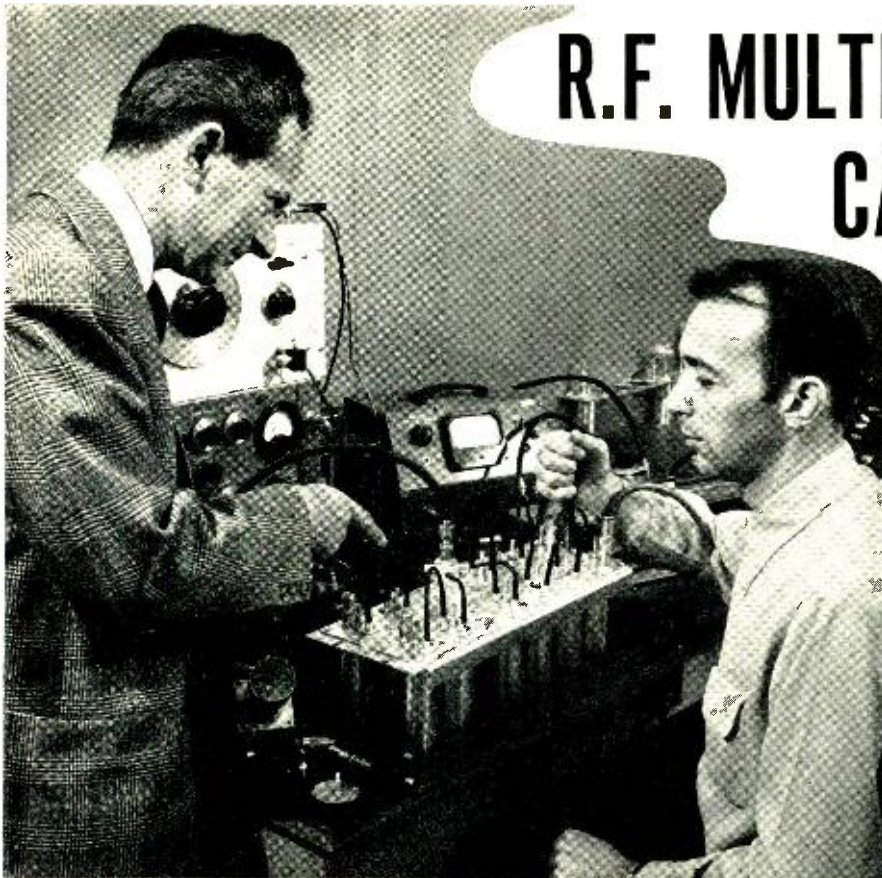
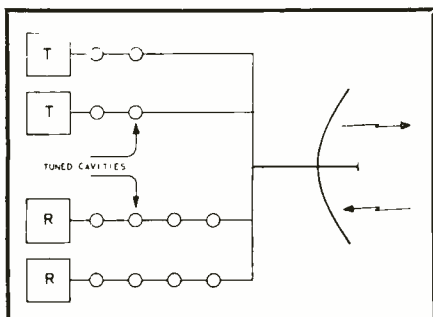

Fig. 1. A set of transmitting and receiving cavity filters being tuned.

*With radio frequency combining techniques, a single antenna can be used with more than one radio terminal.*

**R**ADIO circuits can be combined for transmission over a common antenna in much the same way that telephone circuits are combined for transmission over a common line. However, when more than two circuits are to be operated over the same route, practical considerations usually require that the receivers be operated from one antenna and the transmitters from another. With presently available *Lenkurt* radio equipment for the 900-mc. band, up to three transmitting and three receiving frequencies are used over a

Fig. 2. Block diagram of two transmitters and two receivers diplexed over a common antenna by the use of directional filters.



single multisection route at the same time.

Operation of more than one radio transmitter or receiver over one antenna, called multiplexing, is made possible by the use of tuned cavity directional filters. These filters perform the same circuit function at microwave frequencies that conventional coil-capacitor directional filters perform at carrier and voice frequencies. They prevent mutual loading between individual transmitters or receivers, reduce the output of modulation products from transmitters, and prevent overloading of the receivers by unwanted out-of-band signals.

Three combinations of transmitters and receivers are commonly used in *Lenkurt* microwave systems: a single transmitter and receiver on one antenna; two transmitters and receivers on one antenna; and three transmitters on one antenna with three receivers on a separate antenna. In every case, separate frequencies are required for each transmitter and receiver. With the filters now in use, the minimum frequency separation necessary between any

\*This article is based on material which appeared in the July, 1954, *Lenkurt Demodulator*, published by *Lenkurt Electric Co., Inc.*, San Carlos, Calif.

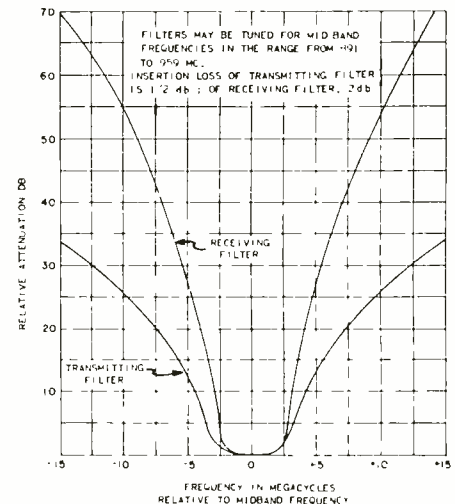

Fig. 3. Curves showing the frequency response of transmitting and receiving filters. Two series cavities are used for transmitting and four for receiving.

transmitter and receiver is normally about 12 mc.; between any two transmitters or any two receivers, it is about 6.3 mc. This separation is dictated primarily by the directional filter characteristics shown in Fig. 3.

The transmitting filters consist of two individual cavities connected in series, while the receiving filters consist of four cavities connected in series. Only two cavities are required for the transmitter filters because their principal functions are to reduce the output of modulation products and prevent mutual loading. The receiving filters must also screen out out-of-band signals that may be picked up by the antenna. Figure 2 shows how tuned cavity directional filters are used to connect two transmitters and two receivers to a common antenna.

Maximum use of the 900-mc. band for the operation of microwave communications over a common path with several repeaters is achieved with three radio circuits in parallel. For a single hop system, additional parallel radio circuits can be operated between two points. By the use of two antennas per terminal (one for transmitting and one for receiving) and presently available *Lenkurt* single-sideband equipment, up to 168 channels can be transmitted and received over a multisection route at the same time.



are you fighting space?

connect  
with  
cannon!

Are you looking for complete electrical circuit dependability in a very, very small space?

If so, you should use Cannon carefully engineered miniature and sub-miniature multi-contact connectors. In  $\frac{1}{2}$  or  $\frac{1}{3}$  the usual space, they give you up to 50 contacts, the same number as a standard connector, and still retain all the factors of utility, reliability, and mechanical strength found in Cannon's standard size connectors. They are very rugged, easy mating, unusually versatile, neat and compact.

Miniatures—Maximum Dimensions Only 1" x 2"!

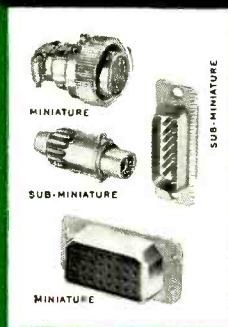

High-dielectric insulation. Rack, panel, chassis types . . . receptacles and plugs, standard, pressurized, or hermetically sealed . . . box, wall or cord mountings . . . for audio, control, and instrument use. D and K sub-miniatures have steel shells. DPA and K miniatures have die-cast shells. Five-ampere gold plated contacts are found in all miniatures and sub-miniatures, excepting U receptacles, which have steel contacts. Larger contacts having higher current ratings, and co-ax contacts, are in process of development.

Sub-Miniatures—Only 2-5/8" x 39/64"!



first in connectors

**CANNON  
PLUGS**

Write for Cannon Miniature and Sub-Miniature Bulletins

Please refer to Dept. 401

CANNON ELECTRIC COMPANY, 3209 Humboldt Street, Los Angeles 31, California.

Factories in Los Angeles, East Haven; Toronto, Canada; London, England.

Representatives and distributors in all principal cities at your service.



# COMMUNICATION REVIEW

## RADIO WEATHER FORECASTS

Unusually good radio conditions for international communications which have recently prevailed are expected to continue for the balance of the year, with only a few moderate disturbances of short duration, according to John H. Nelson, radio-wave analyst of *RCA Communications, Inc.*, 60 Broad St., New York 4, N. Y. Mr. Nelson, who bases his forecasts of magnetic storms on the position of the planets in relationship with each other and with the sun, had a record of 92% accuracy during the first six months of 1954.

Circle No. 51 on Reader Service Card

## SQUELCH UNIT

A codan squelch unit that activates a normally silent Super Pro-600 *Hammarlund* receiver at a predetermined signal strength is now available from *The Hammarlund Manufacturing Company*, 460 West 34th St., New York 1, N. Y. Completely self-contained, it is packaged as an adapter with plug to match one of the existing tube sockets, and obtains its power from the receiver.

The unit's threshold of operation is adjustable to any predetermined level



within the range of r.f. signal inputs of .5 to 100 microvolts. A change in signal carrier level of 2 db or less will complete the switching action of the squelch regardless of threshold setting.

Circle No. 52 on Reader Service Card

## RADIO ON THE ATLANTIC

Extensive radio equipment was installed aboard the converted lifeboat "ARIES" before it set sail on its "double crossing" of the Atlantic Ocean from

Kingston-on-Thames, England, to Kingston-on-Hudson, U.S.A., and back. The equipment was furnished by *Rees Mace*



*Marine Ltd.*, division of *Pye, Limited*, Cambridge, England, and consisted of a newly designed Admiralty-type communications outfit known as transmitter Type 619 and receiver CAT. It made possible continuous communication with Royal Naval wireless stations throughout the world and with many Royal Navy ships on the high seas.

Circle No. 53 on Reader Service Card

## MOBILE SYSTEM FOR 144-174 MC.

The third in a series of three mobile transmitter-receiver systems—Type MCA-301-A—has now been announced by *Allen B. Du Mont Laboratories, Inc.* Covering the 144-174 mc. band, this unit is a complete mobile system which meets all requirements of high stability and ease of maintenance.

Specifically designed to withstand the hard usage of mobile service, Type MCA-301-A is suitable for taxi cabs, forestry service, police, fire department and industrial use. Additional details may be obtained from the Mobile Communications Department, *Allen B. Du Mont Laboratories, Inc.*, 1500 Main Ave., Clifton, N. J.

Circle No. 54 on Reader Service Card

## MODULATION METER

Because of the rapid development of two-way radio equipment using the 450-470 mc. band, the new Model 205A FM modulation meter is expected to answer a definite need in two-way radio maintenance. With a range of 25 to 500 mc., it has five times more sen-

sitivity than the Model 205, which it replaces, and much better limiting action extending over a 500 to 1 range of input level.

Announced by *Lampkin Laboratories, Inc.*, Bradenton 15, Florida, the Model 205A measures FM deviation from  $\pm 0$  to 25 kc., with an accuracy within 10% of full scale on a 3" meter calibrated in kc. It can also be used as a relative field-strength meter when making transmitter adjustments.

Circle No. 55 on Reader Service Card

## COMMUNICATIONS TUBE

Intended for use in communications equipment and telephone repeater systems, the 9-pin miniature pentode tube announced by *American Radio Company* features extremely long operating life. The long life and excellent reliability are achieved by means of a patented "Polioptic" manufacturing process which prevents contamination of the tube elements during processing.

Designated as the 404A, this new electron tube employs an oxide-coated cathode, with a heater rating of 6.3 volts, 0.30 amperes. Maximum anode voltage is 180 volts, and anode dis-

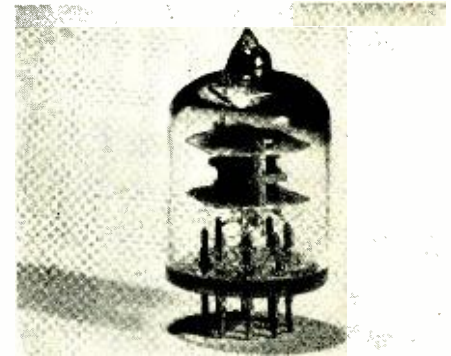

sipation 3 watts. Inquiries should be addressed to *American Radio Company*, Dept. 127, 445 Park Ave., New York 22, N. Y.

Circle No. 56 on Reader Service Card

## LINK IN PRODUCTION

*Link Radio Corporation*, 125 West 17th Street, New York 11, N. Y., a new company organized under the laws of New York, has taken over complete rights and title to all of the assets of the former *Link Radio Corporation* of Delaware. Production lines are now in full swing for all types of past and present *Link* mobile radio communication equipment.

The new company is owned and operated exclusively by Murray Platt, president. James B. Ferguson is chief engineer, and Paul H. Bellingham and Robert W. Fisher are assistant chief engineers.

Circle No. 57 on Reader Service Card





# Ampex magnetic tape recorders

## ...lasting quality for every professional use



- Frequency Response – 40 to 15,000 cps.
- Tape Speed –  $7\frac{1}{2}$  in/sec.
- Signal-to-Noise – over 55 db.
- Flutter and Wow – under 0.25%.

Ampex machines are built with sustained quality and durability – the prime requirements of the major broadcast networks and recording studios. These perfectionists have chosen Ampex, some as long as six years ago, and their machines are still in use today. For example, one Ampex, after 18,000 hours of heavy duty still maintains performance equal to published specifications for new machines! This is the kind of lasting value that is the Ampex standard of excellence in sound recording.

### MODEL 600 • THE NEWEST AMPEX

The Ampex 600 is a portable model that weighs less than 28 pounds. It is an Ampex in design and performance and gives the same class of fidelity, accuracy of timing and reliability as other Ampex recorders. It is the ideal instrument for radio stations, music conservatories, educators, high fidelity enthusiasts and other professional and semi-professional users.

### SERIES 300 • THE FINEST AMPEX

The 300 Series comprises the most perfect sound recording machines yet offered by any manufacturer. They are unexcelled for performances deserving the finest recording and reproduction it is possible to make. Superb design and flawless mechanical stability achieve the utmost in program fidelity, operating reliability and timing accuracy.



- Frequency Response – 30 to 15,000 cps.
- Tape Speed –  $7\frac{1}{2}$  and 15 in/sec.
- Signal-to-Noise – over 60 db.
- Flutter and Wow – under 0.1%.

### SERIES 350 • THE MOST VERSATILE AMPEX

The 350 Series is universally preferred for original and delayed broadcasts, exchanging taped programs, music and drama rehearsals and other performances requiring extensive cueing and editing. Tape editing is remarkably fast with "feather touch" controls mounted within easy reach on a 30°-slanted top-plate. The 350 Series is unusually accessible for installation and servicing, and is available in a variety of tape speeds and mounting styles.



- Frequency Response – 30 to 15,000 cps.
- Tape Speeds –  $7\frac{1}{2}$  and 15 ips, or  $3\frac{3}{4}$  and  $7\frac{1}{2}$  ips.
- Signal-to-Noise – over 60 db.
- Flutter and Wow – under 0.2%.

### MODEL 450 • FOR BACKGROUND MUSIC

The Model 450 is a reproducer which provides sustained high fidelity background music anywhere. It is ideal for the finer hotels, restaurants, department stores, funeral parlors, factories and other users of pre-recorded programs. It plays continuously for 8 hours. Starting, stopping, reversing and repeating can be controlled automatically.



- Frequency Response – 50 to 7,500 cps.
- Tape Speed –  $3\frac{3}{4}$  in/sec.
- Signal-to-Noise – over 50 db.
- Flutter and Wow – under 0.4%

### SERIES S-3200 • FOR TAPE DUPLICATION

This Series of machines achieves true mass duplication of previously recorded tapes while preserving the superb fidelity of the master recording. Up to 10 exact replicas can be made simultaneously, and up to 2500 hours of program material can be produced in an 8-hour day (or one hour in 10 seconds!). The S-3200 Series duplicates both single and double track masters and 2 track stereophonic tapes, of any standard speed, in one pass either "forward" or "backward."



- Frequency Response – 30 to 15,000 cps.
- Tape Speed – 30 and 60 in/sec.
- Signal-to-Noise – over 45 db.
- Flutter and Wow – under 0.2%.

**AMPEX**  
CORPORATION

WRITE FOR FURTHER INFORMATION AND COMPLETE SPECIFICATIONS TO DEPT. T-1723

934 Charter Street • Redwood City, California

Branch offices: New York, Chicago, Atlanta, San Francisco and College Park, Maryland (Washington D.C. area)

Distributors in principal cities (Listed in Telephone Directory under "Recording Equipment")  
Canadian General Electric Company in Canada

For more information, circle No. 7 on Reader Service Card

# NEW PRODUCTS

## MICROWAVE TEST SET

A compact, easy-to-operate microwave testing instrument, designed to simplify laboratory and production line testing as well as field testing and



maintenance of X-band radar, is now available from the *Kearfott Company, Inc.* The unit is entirely self-contained, except for external connecting cables.

Functions of the X-band test set include means to measure power, observe transmitter spectra distribution, measure frequency, and supply artificial signals. Bandwidth characteristics may also be analyzed, and there is a self-contained square wave generator which aids in making standing wave measurements.

For technical literature, write to *Kearfott Company, Inc.*, Western Manufacturing Division, 14844 Oxnard St., Van Nuys, Calif.

Circle No. 58 on Reader Service Card

## "RADA-NODE"

Where accuracy to a fraction of a db is required in measuring noise figure, the "RADA-NODE," made by *Kay*



*Electric Company*, Pine Brook, N. J., may be employed. The "RADA-NODE" includes a noise source, 30- and 60-mc. amplifiers, calibrated attenuators, and an indicating meter.

The noise source has a frequency range of 5 to 400 mc. with noise diode "A," 100 to 3000 mc. with noise diode "B," and 1200 to 26,500 mc. with gas tubes, in eight bands depending on wave guide size. Range of the noise figure is 0 to 21 db, with an accuracy of  $\pm 0.25$  db. Amplifier gain is 75 db, amplifier bandwidth is 14 mc., and input impedance is 50 ohms. The instrument contains three separate attenuation controls.

Circle No. 59 on Reader Service Card

## EMBOSSED COIL FORMS

Threaded coil forms now being made by the *Resinite Corporation* incorporate a new embossed design to prevent

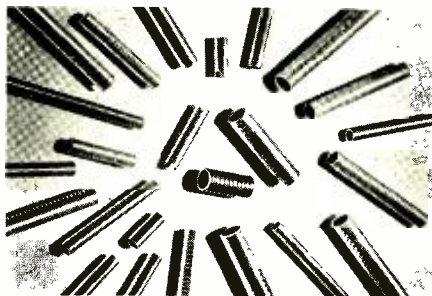

stripping, breakage and freezing due to cross threading or improper starting of the iron core inserts. According to the manufacturer, elimination of these and other torque control problems can increase efficiency of iron core insertion by 20%.

The embossed coil forms are custom-made to the particular iron core specifications, with torque characteristics fitted to the job application. There is no decreasing or deforming of the diameters during production. For further information, contact *Resinite Corporation*, Dept. REE, 2035 W. Charleston St., Chicago 47, Ill.

Circle No. 60 on Reader Service Card

## PRECISION RESISTORS

Production of a new series of "PW" precision wire-wound resistors designed especially for printed wiring assembly techniques and automation has been announced by *Cinema Engineering Company*, Burbank, Calif., division of *Aerovox Corporation*. Entirely encapsulated in an epoxy resin, these resistors meet MIL-R-93A requirements of humidity

protection and aging. They are believed to be the first of their kind offered to the trade.

Simplification of design is featured in the "PW" series, which is available in both subminiature and larger sizes. The smallest resistor has a weight of but one gram and is capable of dissipating 1/10 watt; other units vary



in weight to one ounce, capable of dissipating 1 watt. To eliminate any possible vibration, the larger types are mounted on the printed wiring, and the complete assembly encapsulated.

Circle No. 61 on Reader Service Card

## CASTING RESIN

Stycast 2850 GT is a casting resin for producing electronic embedments which has been developed by *Emerson & Cuming, Inc.*, 869 Washington St., Canton, Mass. In embedding such diverse components as power transformers and transistors as well as complete electronic circuits, it has a temperature range of usefulness extending from  $-100^{\circ}\text{F}$  to  $+400^{\circ}\text{F}$  and for short periods can be used at  $500^{\circ}\text{F}$ .

The cured plastic has a low thermal coefficient of expansion, approximately the same as that of aluminum and brass, which means that even large metallic inserts can be embedded without cracking during temperature cy-

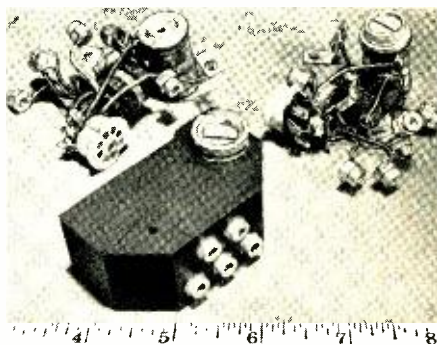

cling. Other features of Stycast 2850 GT are low shrinkage during cure and good adhesion to a variety of materials.

Circle No. 62 on Reader Service Card

## FLOWMETER

With the *Hastings* electronic flowmeter, instantaneous direct readings of gas flow can be made in the 50 to 10,000 cc. per minute range from an in-



indicator small enough to be held in the palm of a hand. The 27-ounce unit was designed by the HICO Instruments Division of the *Hastings Instrument Company*, Warwick, Va., for such applications as process control and quick line checks.

A directly heated thermocouple gage tube can be placed in the line for low flow rates, with practically no pressure drop; logarithmic calibration provides ease of reading in low flow ranges. The instrument may also be calibrated for measurement of mass flow in pounds of air or gas.

Circle No. 63 on Reader Service Card

### SYNCHROSCOPE

The *T.L.G. Electric Corporation* has announced the availability of its new Model C-04 synchroscope. According to

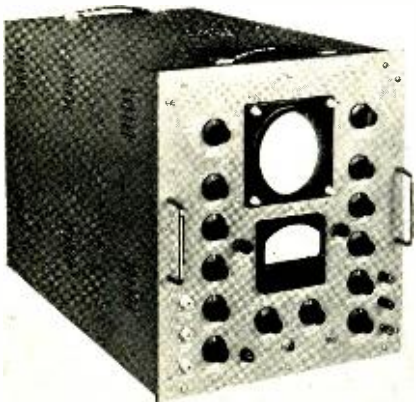

the manufacturer, this instrument represents the first significant redesign of the basic "P-5" synchroscope originally developed by the MIT Radiation Laboratories.

New circuits have resulted in five major improvements: a faster writing rate (0.05  $\mu$ sec. per inch), higher vertical channel frequency response (600 mc. without resonance or distortion), greater stability (a drift of less than 0.4% per month), greatly increased calibration accuracy, and a "stiffer" and faster trigger output.

An illustrated brochure on the Model C-04 may be secured from the *T.L.G. Electric Corporation*, 31 West 27th St., New York 1, N. Y.

Circle No. 64 on Reader Service Card

### ELECTRONIC RELAYS

Two electronic relays which surpass all military requirements for types AN 3303-1 and AN 3304-1 have been developed by the *U. S. Relay Company*. Both 4-PDT continuous-duty relays specifically designed to meet guided missile requirements, the new units can withstand 10 g high frequency vibration. (Continued on page 38)

Circle No. 13 on Reader Service Card

## OPPORTUNITY AT RCA ... FOR BROADCAST FIELD ENGINEERS

RCA needs trained broadcast engineers who can direct and participate in the installation and service of television broadcast equipment. Here's an *excellent* opportunity for training and experience with color TV transmitters.

You need: 2-3 years' experience in broadcast equipment, including work on TV transmitter installation. You should have: EE degree or good technical schooling, 1st Class Radio-Telephone License.

ENJOY RCA ADVANTAGES:

Top Salaries  
Many Liberal  
Company-Paid Benefits  
Relocation Assistance

For personal interview, please send a complete resume of your education and experience to:

Employment Manager, Dept. Y-621  
RCA Service Company, Inc., Camden 2, N.J.



**RCA SERVICE COMPANY, INC.**  
CAMDEN 2, N. J.

For more information, circle No. 12 on Reader Service Card

## UHF Standard Signal Generator

### with Low Hum Level



### MODEL 84-TV

#### FEATURES:

- DC operation of oscillator tube filament.
- Wide continuous frequency coverage.
- Frequency calibration accurate to  $\pm 0.5\%$ .
- Output dial calibrated in microvolts.
- Negligible stray field and leakage.
- Special design mutual inductance type attenuator.
- Low harmonic content.
- Low residual hum modulation.

#### USES:

The versatility of this instrument makes it adaptable to many applications within its frequency range; for driving slotted lines and other impedance measuring devices; for measuring the characteristics of UHF filters, traps, antennas, matching networks and other devices.

#### SPECIFICATIONS:

- Frequency Range: 300 to 1000 Mc.  
Frequency accuracy  $\pm 0.5\%$ .
- Output: 0.1 uv to 1.0 v across a 50-ohm load.
- Modulation: 0 to 30% from an internal 1000-cycle oscillator. External modulation from 50 to 20,000 cys. Residual hum modulation less than 0.5%.
- Power Supply: 105 to 125 volts, 60 cycles, 120 watts.
- Leakage: Negligible.

Laboratory Standards



**MEASUREMENTS  
CORPORATION**  
BOONTON · NEW JERSEY

# NEW LITERATURE

## BERYLLIUM COPPER ALLOYS

Basic information on the principal beryllium copper alloys is provided in a new bulletin released by the Industrial Division, *American Silver Company, Inc.*, 36-07 Prince St., Flushing 54, N. Y. Included are the precision mill limits to which beryllium copper strip is produced by this company. Charts and graphs show engineering properties and metal tempers supplied.

Circle No. 65 on Reader Service Card

## TRANSFORMERS

*Perkin Engineering Corporation*, 345 Kansas St., El Segundo, Calif., has announced the availability of a new bulletin, No. T354, which describes its line of transformers, filter chokes and magnetic amplifiers. Photographs show typical transformer units which are rated from 1/2 kva. up to 200 kva. and are designed to meet or exceed AIEE, NEMA and ASA standards.

Circle No. 66 on Reader Service Card

## RADIATION MEASURING EQUIPMENT

Now available from the *Nuclear Instrument & Chemical Corporation*, 229

West Erie St., Chicago 10, Ill., is a 40-page, two-color catalog setting forth its complete line of radiation measuring equipment. Units covered include scalers, count rate meters, Geiger counters, proportional and scintillation counters, and complete radioisotope laboratories.

Circle No. 67 on Reader Service Card

## PRECISION POTENTIOMETERS

In a 12-page bulletin, No. 341, the *Helipot Corporation*, South Pasadena, Calif., has presented a technical paper by D. C. Duncan on "Characteristics of Precision Servo Computer Potentiometers." This paper, which was originally given at an AIEE Conference on Feedback Control Systems, discusses linearity and sets forth data on research, development and trends in precision potentiometers.

Circle No. 68 on Reader Service Card

## ELECTRIC PLANTS

How *Onan* electric plants are used as emergency standby units, for contractors' portable power needs, as magnet chargers for cranes and trucks, and

to supply primary power for a display coach is told in Vol. 10, No. 3, of the *Onan* publication "Power Points Digest." Many interesting installations are described in this two-color, pocket-sized 16-page booklet which will be furnished without charge by *D. W. Onan & Sons Inc.*, Minneapolis, Minn.

Circle No. 69 on Reader Service Card

## AUTOMATIC WAVE ANALYZER

Complete details on the *Davies* automatic wave analyzer are given in Bulletin 54-C, which has just been published by *The Davies Laboratories Incorporated*, 4705 Queensbury Rd., Riverdale, Md. Consisting of six basic units, this analyzer is a highly accurate heterodyne type designed to produce automatically plotted frequency analyses of complex data signals having components in the 3 to 2000 cps range.

Circle No. 70 on Reader Service Card

## X-BAND COMPONENTS

X-band wave guide components and test equipment are illustrated and described in a four-page catalog available from *Transline Associates* (formerly known as *Guideline Associates*), 57 State St., Newark, N. J. Application and design information is given on variable flap attenuators, wave guide terminations, fixed wave guide attenuators, slide screw tuners, etc.

Circle No. 71 on Reader Service Card

## METAL POWDERS

A brief introduction to the art of powder metallurgy is presented in Bulletin No. 1, recently issued by *Plastic Metals Division of the National Radiator Company*, Johnstown, Pa. In addition, the bulletin discusses the general types of metal powder offered by *Plastic Metals*, and stresses the large number of grades required for different applications.

Circle No. 72 on Reader Service Card

## MAGNETIC-PARTICLE TEST UNIT

Operation of the magnetic-particle test unit called "Portaflux" is explained in an illustrated bulletin available gratis from the Research & Control Instruments Division, *North American Philips Company, Inc.*, 750 S. Fulton Ave., Mount Vernon, N. Y. Objects under study are magnetized either by passing a current through the metal or through a surrounding cable in the form of a coil.

Circle No. 73 on Reader Service Card

## MINIATURE I.F. AMPLIFIERS

"Miniature Intermediate-Frequency Amplifiers" is the title of National

## TV-AM-FM SET PRODUCTION

Information based on latest reports from RETMA.

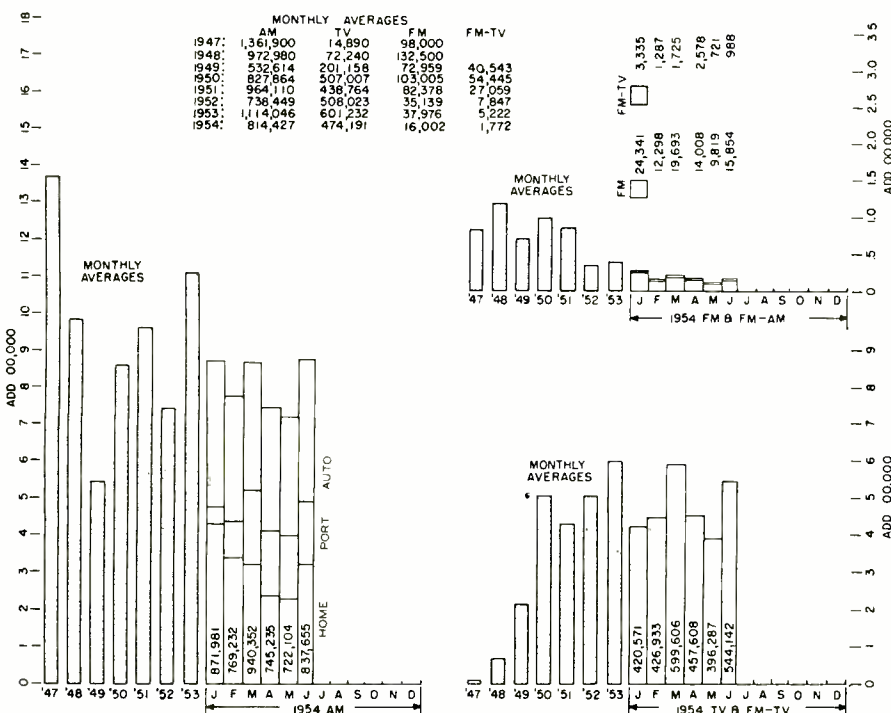



Bureau of Standards Circular 548. Prepared by Robert K-F Seal, it contains 46 pages and 36 figures, and may be obtained from the Government Printing Office, Washington 25, D. C., for 40 cents a copy.

This circular makes available the results of some of the work being done at NBS on the development of miniaturization techniques and their application to airborne electronic equipment. Three miniature high-gain, high-frequency i.f. amplifiers are described which use circuit elements suitable for maximum design simplicity, circuit flexibility, and ease of manufacture.

### MYLAR CAPACITORS

**M**YLAR is one of the various plastics used in the production of dielectric capacitors by *Condenser Products Company*, Chicago, Ill., a division of *New Haven Clock and Watch Company*. Other plastics include cellulose acetate, teflon, polystyrene, and polyethylene. This company has pioneered in research and development of plastic films for use as dielectrics and is now manufacturing such capacitors exclusively.

A film of good dielectric strength, Mylar can be obtained in thicknesses down to  $\frac{1}{4}$  of a mil. Its dielectric constant is relatively high, and it can be used over a wide temperature range; units have been tested successfully at 200°C. Frequencywise, this material is limited somewhat to operation between d.c. and 1000 cps. Its dissipation factor is about .2 to .3% up to temperatures of about 110°C.

Although Mylar capacitors are larger than cellulose acetate capacitors up to approximately 85°C, for a given voltage rating and a given capacity, above this point they are smaller. Perhaps the greatest advantage of this material is its high insulation resistance over a very wide temperature range; insulation resistance at room temperature for a nonimpregnated Mylar capacitor is approximately 1 million megohms and it decreases to approximately 5000 megohms at 125°C.

Circle No. 74 on Reader Service Card

Testing the insulation resistance of a Mylar capacitor in research laboratory.



Circle No. 9 on Reader Service Card

# WIDE-RANGE FREQUENCY METER 85-1000 MEGACYCLES

## TS-175A/U

Government Approved

Calibration Accuracy:  
.005%

Stability:  
.0025%

Resettability:  
.0025%

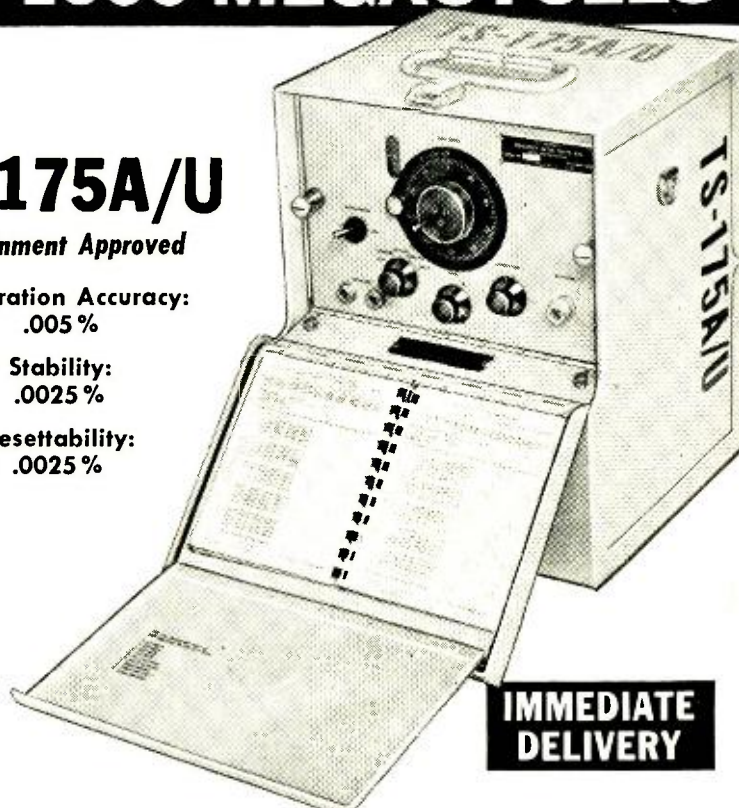

**IMMEDIATE  
DELIVERY**

### A VERSATILE PRECISION MEASURING INSTRUMENT

Recommended Applications:

- Precise Measurements of Frequencies
- Production Testing
- Alignment of Transmitters and Receivers
- Laboratory Testing
- Portable Field Testing
- A Secondary Frequency Standard
- Signal Generator Calibration
- U.H.F. and V.H.F. Television Alignment

**Calibration:** Each instrument is individually calibrated, without interpolation, at 50 Kilocycle intervals throughout its range.

**Frequency Range:** The unit covers the calibrated range of 85 to 1000 megacycles. The fundamental of the precision variable frequency oscillator is 85 to 200 megacycles.

**Sensitivity:** The Frequency meter can detect a radio frequency signal of 20 microvolts with an audio power output up to 50 milliwatts depending on the frequency.

**Internal Modulation:** When desired, amplitude modulation of 1000 cycles in frequency can be employed. The modulation percentage is approximately 30%.

**Radio Frequency Output:** The output voltage from a 50 ohm source, varies from 300 to 100,000 microvolts, within the range of 85 to 1000 megacycles.

**Secondary Frequency Standard:** A 5000 Kc. oscillator incorporating a CR-18/U crystal can be used as a secondary frequency standard with harmonics of 5 megacycles up to 200 megacycles.

Territories for representation available.

We offer a complete automatic recalibration service on all frequency meters.



**COLORTONE**  
ELECTRONICS, Incorporated  
238 William Street, New York, N. Y. • COrtlandt 7-5160  
Executive Offices: 400 Duffy Ave., Hicksville, Long Island

# TECHNICAL BOOKS

**"ENGINEERING ANALYSIS—An Introduction to Professional Method"** by D. W. Ver Planck and B. R. Teare, Jr., Carnegie Institute of Technology. Published by *John Wiley & Sons, Inc.*, 440 Fourth Ave., New York 16, N. Y. 344 pages. \$6.00.

Serving as a guide to the professional method of dealing with an engineering problem, this book was written to aid in the teaching of courses in engineering analysis. The major objective of such courses is the development of the student's capacity to deal with situations that are new to him, by the application of fundamental principles, on his own initiative, and with well-ordered thought processes.

The book provides students with an opportunity to read and reread examples of how problems are formulated, how the attack is planned and executed, and how the results are checked. Examples have been selected to illustrate the application of many of the fundamental principles most useful in engineering practice. The form in which the analyses are presented is that which an engineer might use in his own notebook. Relatively simple and general techniques have been employed.

**"PROCEEDINGS OF THE SYMPOSIUM ON AUTOMATIC PRODUCTION OF ELECTRONIC EQUIPMENT."** Published by Stanford Research Institute, Stanford, Calif. 119 pages. \$4.00.

In recent years, nation-wide effort has been concentrated on the development of techniques to manufacture electronic equipment automatically. A Symposium, jointly sponsored by the U. S. Air Force and Stanford Research Institute, was held on April 19 and 20, 1954, in San Francisco, Calif., to promote collective thinking and the cooperation of material processors and manufacturers of electronic components, electronic equipment, and automatic machinery. Approximately 400 representatives from the management and technical levels of industry and the military participated.

This volume contains the 17 papers presented at the Symposium, together with illustrations, which relate to: (1) general aspects of automation; (2) product design, construction techniques, materials, and components; and (3) design of automatic production lines. A transcript of the Symposium's concluding panel discussion is also included.

**"ELECTROMAGNETIC THEORY"** by V. C. A. Ferraro, Professor of Mathematics, Queen Mary College, University of London. Published by *The Athlone Press*, London. Distributed in the United States by *John de Graff, Inc.*, 64 West 23rd St., New York 10, N. Y. 555 pages. \$7.00.

The purpose of this book is to give an account of the science of electromagnetism from a mathematical point of view. Intended for use by students reading for an Honors degree in mathematics, it contains the substance of lectures on electricity and magnetism delivered over a number of years at King's College, London. Vector methods have been used throughout, with an introductory chapter on vector analysis covering those portions of the subject needed in electricity.

Divided into three parts, the text deals first with electrostatics and magnetostatics, then with the solution of so-called boundary-value problems involving the use of special mathematical methods, and finally with electrodynamics. Although this book has been written primarily for mathematicians, it should also be of use to physicists and electrical engineers.



# MINIATURIZING YOUR EQUIPMENT?

Specify SIMPLEST, MOST COMPACT

## AMPERITE THERMOSTATIC DELAY RELAYS

MOST ECONOMICAL, HERMETICALLY SEALED



STANDARD



MINIATURE

Provide delays ranging from 2 to 120 seconds.

- Actuated by a heater, they operate on A.C., D.C., or Pulsating Current.
- Hermetically sealed. Not affected by altitude, moisture, or other climate changes.
- Circuits: SPST only — normally open or normally closed.

Amperite Thermostatic Delay Relays are compensated for ambient temperature changes from  $-55^{\circ}$  to  $+70^{\circ}$  C. Heaters consume approximately 2 W. and may be operated continuously. The units are most compact, rugged, explosion-proof, long-lived, and — very inexpensive!

TYPES: Standard Radio Octal, and 9-Pin Miniature.

PROBLEM? Send for Bulletin No. TR-81

# BALLAST-REGULATORS

- Amperite Regulators are designed to keep the current in a circuit **automatically regulated** at a definite value (for example, 0.5 amp).
- For currents of 60 ma. to 5 amps. Operates on A.C., D.C., or Pulsating Current.
- Hermetically sealed, light, compact, and most inexpensive.

Maximum Wattage Dissipation:  
T6½L—5W. T9—10W.



T9 BULB

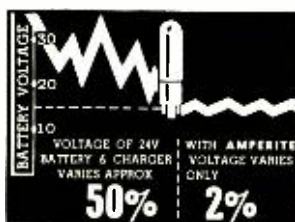
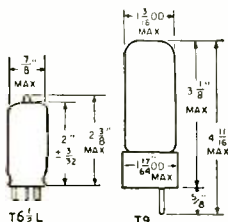

Amperite Regulators are the simplest, most effective method for obtaining **automatic regulation** of current or voltage. **Hermetically sealed**, they are not affected by changes in altitude, ambient temperature ( $-55^{\circ}$  to  $+90^{\circ}$  C), or humidity. Rugged; no moving parts; changed as easily as a radio tube.

Write for 4-page Technical Bulletin No. AB-51

**AMPERITE CO. Inc.**, 561 Broadway, New York 12, N. Y.  
In Canada: Atlas Radio Corp., Ltd., 560 King St., W., Toronto 2B

For further information, circle No. 10 on Reader Service Card



# NEC ANNIVERSARY

A GUEST EDITORIAL

*The National Electronics Conference will celebrate its Tenth Anniversary this year.*

By **RODOLFO M. SORIA**

President, 1954 National Electronics Conference

**T**HE annual National Electronics Conference to be held at the Hotel Sherman in Chicago, Ill., on October 4, 5 and 6, will represent the Tenth Anniversary of this now well-known national forum for electronic research, development and application.

It was in the spring of 1944 that several educational and engineering groups in the Chicago area got together to discuss the advisability of holding a national Conference correlating the advances then being made in all branches of electronics. While such a feeling was undoubtedly nationwide, the desire for action was particularly strong in the Chicago area, where industry was engaged at that time in a vast production program of vital wartime electronic equipment.

The first conference was held at the Medinah Club (now the Hotel Continental) on October 5, 6 and 7, 1944, under the sponsorship of the Illinois Institute of Technology, Northwestern University, the Chicago Sections of the American Institute of Electrical Engineers and the Institute of Radio Engineers, and the Chicago Technical Society. Approximately 2200 people attended. Fifty-six technical papers were presented and were published in Volume 1 of the Proceedings of the National Electronics Conference. From the very beginning, the publishing of the technical program presented at each Conference in book form has been one of the most important activities of the Conference.

The outstanding success of the initial Conference clearly demonstrated the need and enthusiasm for such a national forum. As a result, the Conference has been held annually along the same general pattern—except for one year's omission (1945) due to wartime travel restrictions—with exhibits being included since the second year. Last year's attendance exceeded 6800; there were 150 booth exhibits and 98 technical papers were presented in 22 technical sessions.

This year, in addition to the technical sessions and exhibits, a special luncheon will be held on Monday, October 4, to celebrate the Tenth Anniversary, to honor the founders, and to present the first NEC award recognizing an outstanding paper presented at a previous Conference. As in former years, a permanent record of the technical papers presented will be made available in book form as Volume 10 of the Proceedings of the National Electronics Conference.

The 1954 Conference will be under the sponsorship of the American Institute of Electrical Engineers, Illinois Institute of Technology, the Institute of Radio Engineers, Northwestern University and University of Illinois, with Michigan State College, Purdue University, University of Michigan, University of Wisconsin, the Radio-Electronics-Television Manufacturers Association and the Society of Motion Picture and Television Engineers participating.



For more information, circle No. 11 on Reader Service Card

**HICKOK**  
*Laboratory*  
**TUBE TESTER**  
ALL VOLTAGES VARIABLE AND METERED



**MODEL 700**  
places and measures separate voltage on each element of a tube.

**MODEL 7001 Null Reading Device:**  
Provides tube test accuracy of 1%.

## TESTS TUBES PER MANUFACTURERS MANUALS AND JAN SPECIFICATIONS

Designed for precise laboratory measurement of the most important vacuum tube characteristic, Transconductance (Mutual Conductance).

This new instrument places a separate voltage on each element of the tube. These voltages can be varied and measured by means of separate variable rheostats and meters in each circuit. AC ripple has been completely filtered out of the plate, screen and grid circuits.

Invaluable for development and research work in studying the behavior of various tubes when used in non-conventional and special circuits.

- Built with HICKOK Highest Quality hand calibrated electrical indicating meters.
- Micromho Ranges: 600, 1500, 3000, 6000, 15,000, 30,000 and 60,000.
- Four Separate Signal Voltages: 1.0, 0.5, 0.1 and 0.05 volts.
- This HICKOK Laboratory Tube Tester is supplied complete and consists of power supply, tube sockets, all necessary leads and accessory material. No additional equipment is necessary.

Write today ... for complete technical details on this most complete and accurate tube tester.

**THE HICKOK ELECTRICAL INSTRUMENT CO.**  
10534 Dupont Avenue • Cleveland 8, Ohio



**BALANCING ROTATING PARTS**

High standards of accuracy and sensitivity in the static balancing of rotating parts, such as cooling fans, helicopter rotors, and other rotors, have been established by *Dean & Benson Research, Inc.*, as a result of the newly developed vertical balancing rod on which *Baldwin SR-4* resistance wire strain gages are bonded. The blades of a 40' helicopter rotor have been balanced to 4 inch-ounces; and a 2000-lb. propeller has been balanced in 15 to 20 minutes, a substantial time reduction for tests of this accuracy.

The measuring instrument for the balancer was developed by *Ruge-deFor-*



*est Inc.*, affiliate of *Baldwin-Lima-Hamilton Corporation*, Philadelphia 42, Pa. Changes in the electrical resistance of the gages under stress are measured by the electronic amplifier and bridge circuits contained in a small indicator cabinet. In the photograph, a small air cooling fan for an aircraft engine is shown being balanced.

Circle No. 75 on Reader Service Card

**SIGNAL CORPS PROMOTION**

Walter H. McDonald, formerly head of the Public and Industry Relations Section in the Office of Technical Liaison of the Signal Corps, has now been appointed chief of the OTL. He succeeds Bruce Quisenberry, who has left the Signal Corps after 12 years of service for a position with the *Automatic Electric Company* in Chicago, Ill.

**CLEVITE RESEARCH CENTER**

In the newly created post of vice president in charge of coordination of research and new product development, John W. Dixon, executive vice presi-

dent of *Clevite Corporation* since 1951, will coordinate the activities of the corporation's new research center with those of the other units in the corporation. Included in the center are two self-contained units, each with its own management: *The Brush Laboratories Company*, the corporation's basic research group, and *Clevite-Brush Development Company*, its product development unit.

The research center, which is scheduled for its official opening this fall, is located at 540 East 105th Street, Cleveland, Ohio, in a building acquired late last year, and brings together some 300 scientists, technicians, and administrative assistants whose work for *Clevite* has previously been conducted in a number of separate places.

**A.C. NETWORK CALCULATOR**

In cooperation with seven major power companies in Pennsylvania, New Jersey and Delaware, the Franklin Institute has put into service a new a.c. network calculator built by the *Westinghouse Electric Corporation*, 401 Liberty Ave., Pittsburgh 30, Pa. This modern computing device, the largest of its kind in the world, will be used by the utilities in solving the many complex problems involved in



maintaining and expanding their power systems.

The power companies concerned in the joint venture are: *Atlantic City Electric Company*, the *Delaware Power and Light Company*, *Jersey Central Power and Light Company*, *Metropolitan Edison Company*, *New Jersey Power and Light Company*, *Pennsylv-*

*ania Electric Company*, and *Philadelphia Electric Company*.

Circle No. 76 on Reader Service Card

**LONG-PLAYING DISC RECORDER**

Up to two full hours of either monitoring or conversation can be had on only one side of an 8" disc with the



constant groove speed and constant amplitude disc recorder developed by *Panamar, Inc.*, of Beverly Hills, Calif. Called the "*Panamar Recorder-Playback*," the machine has been designed to use a vinylite disc, turning at groove velocity of 1½ to 10" per second, and thus permitting a recording time of 120 to 30 minutes respectively.

Simply constructed, it records and plays back through the same stylus and embosses—not cuts—approximately 300 lines per inch. One three-position lever and a two-position knob are the only controls.

Circle No. 77 on Reader Service Card

**NEW G-E DEPARTMENTS**

In accordance with the decentralization program of the *General Electric Company*, the former Meter and Instrument Department at Lynn, Mass., has been divided into two separate organizations: the Meter Department, which will make its headquarters at Somersworth, N. H., where facilities for the manufacture of meters have been in operation since 1948; and an Instrument Department, which will remain at Lynn, Mass.

C. Howard Black, formerly general manager of the Meter and Instrument Department, has been named general manager of the new Instrument Department; while D. E. Craig, previously manager of the Somersworth plant, has been appointed general manager of the Meter Department. I. F. Kinnard will be manager of engineering at Lynn, and G. Rodger Sturtevant will be manager of engineering at Somersworth.

**ELECTRON MICROSCOPES**

During the past 15 years, with the help of the electron microscope and electron diffraction, researchers have



uncovered many of nature's secrets concerning infinitesimal organisms and particles of matter. Today, according to the Research & Control Instruments Division of the *North American Philips Company, Inc.*, 750 South Fulton Ave., Mt. Vernon, N. Y., the most modern electron microscopes employ accelerating voltages from 40 to 100 kv. to magnify tiny specimens 1000 to 80,000 times their actual size.

Cameras are standard accessories for electron microscopes and film techniques readily permit magnifications up to 300,000; the photograph shows how easy it is to insert or remove such a

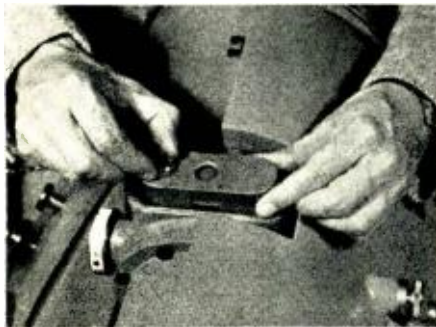

camera. These instruments may be used wherever laboratory or shop problems exist which involve particle identification, structure, size, surface and physical characteristics, dispersion and molecular weights.

Circle No. 78 on Reader Service Card

#### OPEN TRANSFORMERS

Open transformers up to 5 kva. are now being made with an encapsulation material based on *Du Pont's* neoprene synthetic rubber. Coils are encased in tough, vulcanized rubber that doesn't become brittle even at low temperatures, and terminals are sealed by positive pressure.

The insulation resistance of units made with the new neoprene coating consistently exceeds 1000 megohms after 100 humidity cycles, and their 10-cycle insulation resistance is over 50,000 megohms. Such performance is achieved with a 30 to 40% saving in space and

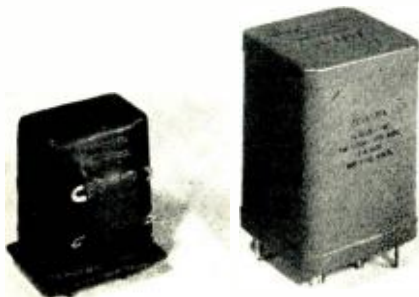

weight, and with a 15 to 25% saving in cost over conventional canned units.

*Aircraft Transformer Corporation,*

West and Willow Sts., Long Branch, N. J., is currently manufacturing transformers by this patented process under the trade name of "Form-Flex." The photograph shows the same grade of military transformer sealed in the neoprene capsule (left) and sealed in a conventional can (right).

Circle No. 89 on Reader Service Card

#### BURROUGHS EXPANDS

*Burroughs Corporation*, Detroit 32, Mich., has announced the acquisition of *Haydu Brothers*, Plainfield, N. J., Manufacturer of electronic tubes and components, "to provide specialized manufacturing facilities needed for the production of new type vacuum tubes and other electronic components developed in the course of *Burroughs* extensive research activities in the electronics field." The company will continue its operations under the direction of George K. Haydu, formerly president, who has now been named general manager.

#### ETCHED CIRCUIT PRODUCTION

Intricate etched circuits for digital computers and other electronic assemblies are now being mass-produced by

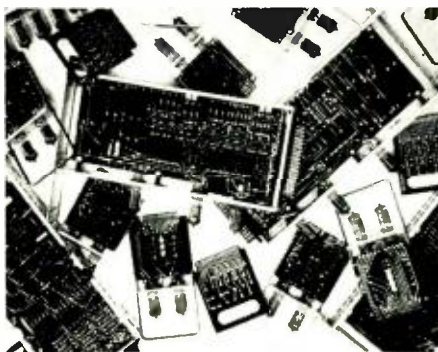

the *Bendix Computer Division of Bendix Aviation Corp.*, Los Angeles, Calif., and are ready for marketing in "package" form. At present, some 13 different types of circuit packages, of different sizes and functions, are being made.

Through the use of photography and silk screen printing of connection and terminal design, *Bendix* etched circuitry makes possible uniformity of product at lower cost. By eliminating hand-wiring, most of the human error that goes along with it is also eliminated, so that testing of individual circuits becomes unnecessary. Etched circuits can be turned out at least 50% faster than hand-wired circuits, and are especially suited for television, telephone equipment and computer manufacture.

Circle No. 90 on Reader Service Card

Circle No. 15 on Reader Service Card

# PLASTIC DIALS

Printloid has been supplying dials to the leaders in the electronic industry for 18 years. Printing, die cutting, forming and machining.

**COMPLETE PLASTIC PRODUCTION FACILITIES . . . ALL UNDER ONE ROOF**

Including machining of Nylon, Kel-F, and Teflon. Specializing in dials, dial windows, and printed circuits.

**All custom work to your specification.**

Write for brochure

Dept R 93 Mercer St.  
New York 12, New York

Circle No. 14 on Reader Service Card

## reduce noise error 99%

**mininoise®**  
ACTUAL SIZE!

Mininoise Cable, made only by Microdot, is ideal for low signal levels and high impedance terminations. In every applicable case, Mininoise reduces noise 99%!

WRITE for data on Mininoise cable and Microdot coax assemblies.

**MICRODOT**  
1826 FREMONT STREET  
50. PASADENA • CALIF.



# NEW TUBES

## SELENIUM DIODES

Four new selenium diodes have been added to the line of subminiature diodes now in production at *International Rectifier Corporation*. Designated as Types 4V1, 5V1, 2Y1, and 3Y1, they are rated

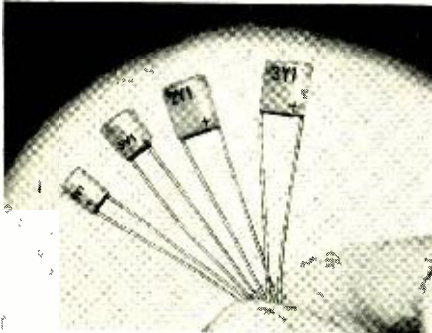

for a maximum a.c. input voltage (r.m.s.) of 52-130 volts, 60-80 volts maximum d.c. output, and will deliver a 5-11 ma. output current.

Each diode is completely encapsulated within a thermosetting plastic and

may be operated in an ambient temperature range of  $-50$  to  $100^{\circ}\text{C}$ . Complete information on these diodes, which may be used to provide bias for tubes in military and commercial electronic equipment, is available from *International Rectifier Corporation*, El Segundo, Calif.

Circle No. 79 on Reader Service Card

## MICROWAVE TUBES

The various types of microwave silicon diodes, magnetrons, TR and ATR tubes and wave guide components available from *Microwave Associates, Inc.*, are listed together with prices in a new four-page leaflet. Diode prices shown are based on quantities not exceeding 25 units, while tube and component prices are for single units. All tubes listed are produced to applicable MIL-E-1B specifications.

Locations of sales representatives throughout the United States are also given in this leaflet, which may be ob-

tained from *Microwave Associates, Inc.*, 22 Cummington Street, Boston 15, Mass.

Circle No. 80 on Reader Service Card

## "ALLERGIC" PHOTOTUBE

Electronically "allergic" to spots before its "eyes," the RCA-6405/1640 phototube was designed for production-line inspection of soft drinks, medical solutions, and similar translucent liquids. The light-sensitive tube reacts to even minute, transparent impurities which may be bottled inadvertently, and automatically triggers an electronic reject system.

Previously available on a custom-order basis from the Tube Division of *Radio Corporation of America*, Harrison, N. J., the phototube has now been added to RCA's commercial line. It has a wide spectral response and can be used with an incandescent light source.

Circle No. 81 on Reader Service Card

## MINIATURE PENTODE

A miniature pentode has been announced by *Raytheon Manufacturing Company* for all applications where the tube must be capable of good life while



operating under very small or zero cathode current. The CK6485 is a heater-cathode type, high-transconductance, sharp-cutoff pentode designed for use as a wide-band or i.f. amplifier. It will maintain its emission and freedom from excessive cathode interface resistance even after long periods of operation under cutoff conditions.

Electrically, the CK6485 is like the *Raytheon* 6AH6, which has high mutual conductance and a good figure of merit. Data for both pentode and triode operation of the CK6485 may be obtained from Technical Information Service, *Raytheon Manufacturing Company*, 55 Chapel St., Newton 58, Mass.

Circle No. 82 on Reader Service Card

## RELAY KLYSTRON

Performance of the VA-220 relay klystron announced by *Varian Associates*

Circle No. 16 on Reader Service Card

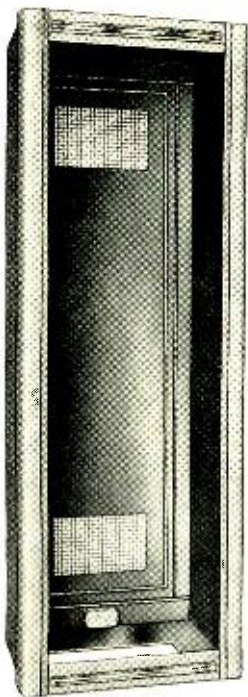

## "P" SERIES RACKS

No. P-3618: Overall:  $42\frac{1}{2}'' \times 22'' \times 18''$   
Panel Space:  $36\frac{1}{4}'' \times 19''$   
No. P-6618: Overall:  $67\frac{1}{2}'' \times 22'' \times 18''$   
Panel Space:  $61\frac{1}{4}'' \times 19''$   
No. P-8318: Overall:  $83\frac{1}{2}'' \times 22'' \times 18''$   
Panel Space:  $77'' \times 19''$

Par-Metal "P" Series Racks are available on special request up to 28" deep.

## "G" SERIES TRANSMITTER RACKS

No. G-2218: Overall:  $76\frac{1}{2}'' \times 22'' \times 18''$   
Panel Space:  $70'' \times 19''$   
No. G-2219: Overall:  $83\frac{1}{2}'' \times 22'' \times 18''$   
Panel Space:  $77'' \times 19''$   
No. G-3024: Overall:  $76\frac{1}{2}'' \times 33'' \times 24''$   
Panel Space:  $70'' \times 30''$

"P" and "G" Series RACKS have standard finishes of black ripple, slate grey ripple (or prime coat only).

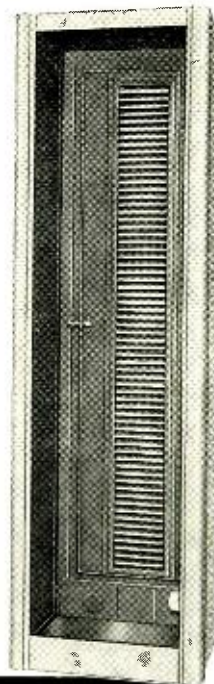

Planning an electronic product? Consult Par-Metal for

**RACKS • CABINETS  
CHASSIS • PANELS**

Made by  
*Electronic Specialists*

**WRITE FOR CATALOG!**



**PAR-METAL**  
PRODUCTS CORPORATION

32-62 — 49th ST., LONG ISLAND CITY 3, N. Y.  
Tel.: ASTORIA 8-8905  
Export Dept.: *Rocke International Corp.*  
13 East 40 Street, New York 16, N. Y.



## Professional Directory

### GEORGE P. ADAIR Engineering Co.

Consulting Engineers

Radio, Television, Communications,  
Electronics

1610 Eye St., N.W. EXecutive 3-1230  
Washington 6, D. C.

Circle No. 17 on Reader Service Card

Paul W. Klipsch  
Professional Engineer  
Acoustic development  
and consulting

Klipsch and Associates  
building the authentic  
KLIPSCHORN  
world's finest sound reproducer

Hope, Arkansas Tel. Hope PProspect 7-3395

Circle No. 18 on Reader Service Card

### FRANK H. McINTOSH

Consulting Radio Engineer

1216 Wyatt Bldg., Washington 5, D. C.  
MEtropolitan 8-4477  
Member AFCEE

Circle No. 19 on Reader Service Card

### MEASUREMENTS CORPORATION

Research &  
Manufacturing  
Engineers

Harry W. Houck John M. Van Beuren M. A. Honnell  
Specialists in the Design and  
Development of Electronic Test Instruments  
BOONTON, N. J.

Circle No. 20 on Reader Service Card

### GABRIEL ELECTRONICS DIVISION

Formerly Workshop Assoc. Div.  
THE GABRIEL COMPANY

Specialists in  
High-Frequency  
Antennas

Endicott St. Norwood, Mass.  
NORwood 7-3300

Circle No. 21 on Reader Service Card

We'll see you at the  
National Electronics Conference  
October 4-6!  
Booth 20

ciates, Palo Alto, Calif., exceeds the high standards set by the Varian X-26 klystron yet it costs only half as much. Exemplifying the most advanced techniques in klystron design and construc-

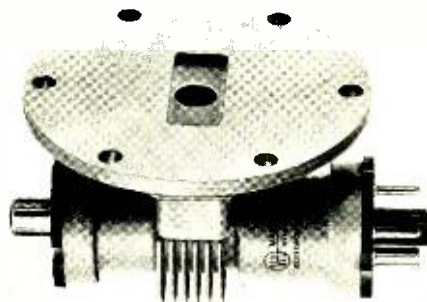

tion, the VA-220 offers significant advantages for all relay applications in the 6000-8000 mc. band.

Features include ample power to override noise, negligible frequency drift, easier tuning, FM distortion and inherent noise 60 db below a 1-mc. deviation, and production uniformity—at a cost far less than that of any other relay klystron of comparable performance. Operating characteristics for the VA-220 line are: frequency range, 5925-7425 mc.; resonator voltage, 750 volts; power output, 1.2 watts; bandwidth, 35 mc.; modulation sensitivity, 375 kc./v.

Circle No. 83 on Reader Service Card

### Pulse Shaper

(Continued from page 13)

physical and electrical specifications. Heat dissipation of components is negligible and 1/2-watt resistors are used throughout. The 5- $\mu$ hy. coil is constructed by closely winding 100 turns of No. 32 enameled wire in three layers using an 0.1-megohm, 1/2-watt carbon resistor as a coil form. Inductance is not critical as the output pulse amplitude is well above the required 75 volts.

In an experimental setup, bias was derived from a filament transformer as illustrated in Fig. 5. The 50- $\mu$ fd. capacitor provides adequate filtering, while the 180-ohm resistor limits the peak current to a safe value for the 1N34 germanium diode. If the full 6.3-volt a.c. winding is used as the input, the open-circuit voltage is 10 volts. Under these circumstances, a 680-ohm load resistor is connected across the output of the bias supply to insure good regulation and drop the output to the required 4 volts.

In the final system, the bias is derived from the same transformer that supplies filament current to the tube. The center-tap is grounded and half of the winding is used in conjunction with a crystal rectifier and filter. For this design, the 680-ohm load resistor should be omitted.

## New Second Edition . . .

completely revised to answer your questions about the latest developments in TV—including COLOR



## TELEVISION

The Electronics of Image Transmission  
in Color and Monochrome

by V. K. ZWORYKIN,  
Director of Electronic Research, RCA Laboratories,  
and G. A. MORTON, RCA Laboratories,  
Princeton, N. J.

This entirely new edition of TELEVISION reflects the tremendous technological advances that have raised TV from a restricted, experimental field to a major industry in the past fourteen years. The well-known authors have completely revised the book, loading it with practical, up-to-date information.

This is the first book to give adequate coverage to color television. Its consideration of both the theoretical and practical aspects is sufficiently detailed to give a sound working understanding of this important new development. The second edition is more than 60% larger than its predecessor and most of the illustrations are new.

Offering as it does a broad and useful understanding of the engineering aspects of TV, this work is a *must* for your library.

1954 1037 pages . . . 728 illustrations \$17.50  
May we send you a copy of  
TELEVISION, Second Edition,  
to read and examine ON APPROVAL

Simply mail the  
convenient coupon below!

JOHN WILEY & SONS, Inc.  
440 Fourth Ave., New York 16, N. Y.

Please send me for FREE EXAMINATION a copy of the new Second Edition of TELEVISION. Within ten days I will either return the book and owe you nothing or will remit \$17.50, plus postage.

Name \_\_\_\_\_  
Address \_\_\_\_\_  
City \_\_\_\_\_ Zone \_\_\_\_\_ State \_\_\_\_\_

SAVE POSTAGE. Check here if you ENCLOSE payment in which case we pay postage. Same return privilege applies, of course. REE-10

Circle No. 22 on Reader Service Card

## Components

(Continued from page 19)

7- and 9-pin types. Solder connections can be made to the tabs from both sides of the chassis.

The other two illustrations in Fig. 8 are bottom and top views of a "long-lead" type of socket. This socket also has a molded body with contact tabs protruding from the bottom and bending upward at approximately a 90° angle. The contacts are held in place by a laminated disc riveted to the bottom. Mounted by means of a retainer ring, this socket is designed primarily for use when the printed pattern is on the top side of the chassis. It should be noted that the tabs and insulator body occupy considerably more area than the tube base.

Figure 10 shows an experimental receiver using four right-angle mounted, flat-press type subminiature tube sockets. Subminiature tubes may be connected to the printed circuit by inserting the leads through eyelets soldered in the printed circuitry or by soldering the leads directly to the printed circuit terminations. When frequent replacement of tubes is necessary, this procedure is inconvenient and it becomes necessary to use tube sockets. Sometimes, limited space above the chassis requires that the tubes be mounted parallel to the chassis, thus necessitating the use of a right-angle mounted socket.

Several subminiature sockets of both the button and flat-press types, for both right-angle and vertical mounting in printed circuit applications, are available commercially. Although these units are undoubtedly satisfactory for many commercial applications, testing has indicated that improvement is needed before they may be regarded as fully acceptable for military applications. Improvements are needed in the contacts which presently lack the flex features and insertion and withdrawal life features required for more rigorous applications. However, sockets of this

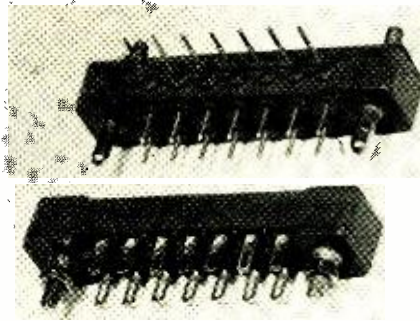

Fig. 13. Right-angle plug and receptacle presently being used in printed circuit applications.

type have been employed in some experimental military equipment and in many commercial electronic devices.

The individual printed circuit cards forming equipment subassemblies may be interconnected by wires or by an integrating printed circuit board bearing the necessary conductors. In either case, if the subassemblies are to be readily replaceable, some connecting device must be employed. Printed circuit subassemblies have been interconnected by means of conventional plugs and receptacles on many occasions. The following devices are among those presently being used by industry and the Services.

A printed card with a printed circuit receptacle is shown in Fig. 11. When this type of connector is used, the male contacts are printed on the circuit board. The receptacle illustrated contains 15 precision-machined, spring-tempered, phosphor-bronze contacts. A polarization key can be substituted for any one or more of the contacts, with a keyway cut in the circuit card to mate with the polarization key in order to eliminate the possibility of improper insertion. The unit is molded of mineral-filled melamine. Testing has indicated that the electrical characteristics of this receptacle (dielectric breakdown and insulation resistance between contacts, and the contact resistance between the printed conductors and receptacle con-

tacts) are of the same order as those of the JAN-type electron tube socket. The receptacle contacts also have good life properties. Since the receptacle makes direct contact with the printed circuitry, it is not possible to coat protectively the contact-making portion of the circuitry. This portion of the card may therefore be more susceptible to electrical failure under conditions of high humidity. Such units can be obtained with 2 to 31 contacts. Versions of this type of receptacle are commercially available in slightly different configurations and with other contact and insulator body materials (see Fig. 12).

The receptacles in Fig. 12 are each utilized for purposes of making a connection from the card to conventional wiring. It is sometimes desirable to integrate subassemblies by means of a "card-to-card" connection. At the present time, there are no known commercially available connectors for accomplishing this type of mating.

Various types of conventional internal rack and panel connectors have been successfully utilized in printed circuit applications (see Fig. 13). When such devices are used, terminations with perforations are provided on the printed circuit card to receive the pins of the plug. Attachment is effected by solder-dipping, as with other components. The plug with the printed circuit card attached is then inserted into the receptacle. When this type of construction is used, the added cost of a plug must be considered. However, this arrangement allows the entire printed circuit area to be protected by a coating. Connections are available with a large number of contacts and with various pin layout configurations. Since the receptacles of these connectors have "float" and the soldering tabs are movable, it is not possible to use them for card-to-card integration.

While conventional or modified electromechanical components are in most instances compatible with Auto-Semby, components designed specifically for printed circuit applications have inherent characteristics that are congruous with the system. To obtain components with these characteristics and with the ability to withstand the rigorous environmental conditions imposed by military requirements, a program was initiated by Signal Corps Engineering Laboratories to develop a family of such electromechanical components. Some of the components discussed above may be considered as interim items until such time as this program or industrial development activities provide components capable of meeting completely the severe requirements of military applications.

Circle No. 23 on Reader Service Card

**MONITORADIO** for a thoroughly coordinated 2-way communication system.

Now every member of every department can have radio communication for as little as \$49.95

Write today for further information.

**MONITORADIO RADIO APPARATUS CORPORATION**  
55 North Jersey St., Indianapolis, Ind. Phone: Atlantic 1624

got enough **EARS?**

**BE ON THE CONSTANT ALERT**

All Departments Can Now Listen to Every Vital Message

- Nation's most complete line of monitor receivers.
- Crystal controlled or tunable for any VHF FM communication system.
- Mobile or stationary receivers.
- Prices to meet any budget.
- Certified for civil defense use.



## Narrow Band

(Continued from page 16)

ing the receiver r.f. and high i.f. amplifiers as selective as possible. The perfect receiver would be one in which all of the selectivity lies ahead of the first tube grid. Since that is not practical, it is necessary to resort to the double-superheterodyne technique and use minimum gain in the inherently less selective stages.

It is particularly difficult to obtain good r.f. selectivity in the 150-mc. band because of the loading imposed on the tuned circuits by the relatively low input impedance of vacuum tubes at those frequencies. Therefore, when additional selectivity is required in a particular installation, it is obtained by the use of cavity resonators—which are of practical size in 150-mc. operation. This solution is not attractive in the 25-50 mc. band due to the "king size" of a cavity at those frequencies. For this reason, all the r.f. and high i.f. selectivity that well-designed, multiple-tuned circuits can provide has been incorporated in the *G-E* receiver.

In this receiver, two tuned circuits are employed between the antenna and r.f. grid and three tuned circuits are employed between the r.f. tube and the first converter—five high *Q* tuned circuits in all. They are followed in the high i.f. amplifier by two triple-tuned transformers which are very effective in "dropping out" off-channel signals.

### Recommendations

If all necessary channels are available, the use of present wide-band operation should be continued. On the other hand, if a particular industry's channels are saturated, instead of resorting to shared-channel operation, split-channel operation should be utilized on a developmental basis if necessary. In congested areas, a new user would be making the conservative choice in starting right off with narrow-band equipment even though he might presently be licensed for a 40-kc. channel.

An existing wide-band system should not be expanded by adding a relatively few narrow-band mobile units but should be used as wide-band until the entire system is ready to be changed. It is not difficult to convert present-day units from one type of operation to the other. If a mixed system of wide-band and narrow-band equipment is decided upon, all transmitters should be reduced to the compromise setting of  $\pm 10$  kc. maximum.

In general, base stations are more vulnerable to interference than mobile units because of their advantageous location. In going to narrow-band operation, it may only be necessary to reduce the swing of all transmitters in the system and to replace just the base station receiver with an up-to-date narrow-band receiver. With favorable geographic separation, it may be possible to continue the use of wide-band mobile receivers.

Time and effort should be spent to reduce ignition noise and other sources of car noise. A coaxial-type capacitor and/or a choke should be used on the generator. If this is not done, a noise generator will be carried right along with the radio equipment, limiting reception range.

The center frequency adjustment on new transmitters or receivers as received from the factory should not be altered except with very accurate and reliable frequency measuring equipment; before shipment, they are set to exact frequency. In narrow-band operation, exact carrier frequency is more important than in wide-band operation to obtain best signal-to-noise ratio and to avoid adjacent channel interference. The base station transmitter should make a good system standard; its frequency can be compared with other transmitters in the system by means of receiver discriminator readings.

For more information, circle No. 25 on Reader Service Card

# ZOPHAR WAXES COMPOUNDS

Zophar waxes, resins and compounds to impregnate, dip, seal, embed, or pot, electronic and electrical equipment or components of all types; radio, television, etc.

Cold flows from 100°F. to 285°F.

Special waxes non-cracking at -76°F.

Compounds meeting Government specifications, plain or fungus resistant.

Let us help you with your engineering problems.



**ZOPHAR MILLS, INC.**  
112-130 26th Street,  
Brooklyn 32, N. Y.

For more information, circle No. 24 on Reader Service Card

## RESINITE

.. can increase  
efficiency of  
your iron core  
insertion  
production  
by 20%

### EMBOSSED COIL FORMS

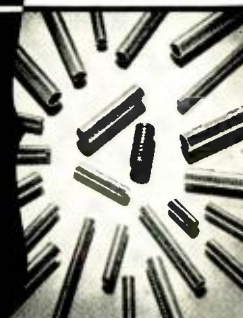

Special embossed construction eliminates torque control problems and stripping. Custom fabrication to your exact specification assures correct dimensions to within the most critical tolerances.

We will furnish—without charge—a pilot production run of custom-made embossed forms to fit your particular application.

Contact us now for full details about this special offer. Request technical bulletin, *Use of Threaded Tubes, Threaded Iron Cores VS. Torque Control.*

**RESINITE  
CORPORATION**

#### Sales Representatives in:

|   |   |
|---|---|
| <b>New England:</b><br>Framingham, Mass., Framingham 7091                         | <b>Philadelphia:</b><br>Philadelphia, Pa., Chestnut Hill 8-0282                 |
| <b>New York, New Jersey:</b><br>Jersey City, New Jersey,<br>Journal Square 4-3574 | <b>Northern Ohio, Western Pennsylvania:</b><br>Cleveland, Ohio, Atlantic 1-1060 |
| <b>Upstate New York:</b><br>Syracuse, N.Y., Syracuse 76-8056                      | <b>Indiana, Southern Ohio:</b><br>Logansport, Indiana, Logansport 2555          |
| <b>Maryland:</b><br>Baltimore, Maryland, Plaza 2-3211                             | <b>Missouri, Southern Illinois, Iowa:</b><br>St. Louis, Missouri, Sterling 2318 |
| <b>Canada:</b> Montreal, Quebec, Canada, Walnut 2715                              | <b>California:</b><br>Pasadena, California, Sycamore 8-3919                     |



**PRECISION PAPER TUBE COMPANY**  
2035A W. CHARLESTON ST. • CHICAGO 47, ILLINOIS

# Personals



**E. FINLEY CARTER**, vice president and technical director of *Sylvania Electric Products Inc.*, has accepted the position of manager of research operations at Stanford Research Institute, Stanford, Calif. In this new position, Mr. Carter will supervise the three research divisions carrying SRI's main programs and projects—Physical Sciences, Engineering, and Economics. He will retain an association with *Sylvania* on a consulting basis.



**CLIFTON H. DAVIS**, as assistant chief engineer of *Neomatic, Incorporated*, Los Angeles, Calif., will be directly concerned with current design engineering problems and new product research and development work. Mr. Davis has had over 23 years of engineering experience in the radio and electronics field, much of this time being spent with the U. S. Navy in various capacities. He recently served as chief electronics engineer for the *Globe Corporation*.



**S. H. DODINGTON**, who has been with *Federal Telecommunication Laboratories*, Nutley, N. J., a division of *International Telephone and Telegraph Corporation*, since 1941, has now been appointed laboratory head in charge of the Radio Navigation and Radio Equipments Laboratory. Long associated with the development of airborne navigation systems, Mr. Dodington holds over 20 patents covering his important contributions to the field.



**ANDREW S. KARIOTIS** has joined the field engineering staff of the Washington, D. C., office of the *Sprague Electric Company*, North Adams, Mass., where he will be engaged in government contact work on electronic components. A graduate of the Massachusetts Institute of Technology and a member of the MIT engineering honorary society, Mr. Kariotis served for three years with the U. S. Coast Guard as an electronics technician.



**GERHARD G. SCHNEIDER**, well known in the electronics industry for his development of automatic tube-making machinery and equipment, has been elected vice president in charge of production at *National Union Electric Corp.*, Hatboro, Pa. Associated with *National Union* since 1934, Mr. Schneider holds patents on machines for automatic grid winding, electronic tube base making, heater folding and inserting, tube sealing, and many others.



**FRAZIER O. STRATTON** has been named chief engineer of *Sterling Engineering Company*, Laconia, N. H., subsidiary of *American Machine & Foundry Company*. Prior to joining this company as assistant sales manager in 1953, Mr. Stratton served in various engineering capacities for *C. P. Clare Company*, *Automatic Electric Company*, and the New York Stock Exchange. He received his B.S. degree in electrical engineering from Cooper Institute of Technology.

## Citizens Radio

(Continued from page 9)

tions used in other radio services operating in the adjacent 450-460 mc. band. At this time, equipment available for both services is identical except for specific operating frequencies.

A typical 460-mc. mobile radio unit for installation in a motor vehicle consists of the same major components as a mobile radio unit for operation in the 25-50 or 152-162 mc. bands, i.e., transmitter-receiver unit, antenna, control unit, microphone, and loudspeaker. The exterior appearance of the transmitter-receiver unit is similar, and power and cabling requirements are almost identical. The antenna, however, is only one-third the length of the 18" rooftop whip used in 152-162 mc. service. Also, at 460 mc. ignition noise problems seldom exist.

Fixed radio systems consist of two or more radio stations within intercommunication range of each other. Class A and B stations may be used for the transmission of telephone, telegraph, teleprinter and facsimile intelligence. Thus, it appears to be permissible to multiplex the radio carrier to derive more than a single voice channel provided the maximum bandwidth of the radiated radio signal is kept under 200 kc. By exercising ingenuity, and through the selection of suitable equipment, a pair of fixed stations can be utilized to handle more than one voice channel simultaneously, plus one or more telegraph or teleprinter functions.

The expansion of the Citizens Radio Service presents new opportunities to radio service organizations. Radio communications equipment requires competent maintenance. The test equipment and training required are essentially the same as those required for servicing police, taxi, and other mobile radio equipment.

Higher powered class A transmitters available today are tunable, usually anywhere in the band, and require the proper crystals for the specific frequency of operation. To comply with FCC rules, the transmitter must be tuned and the power supply limited so that power input to the final r.f. stage

Table 1. Citizens Band frequency allocations as authorized by FCC.

| Class of Station | Frequency (mc.) | Power Input (watts) | Frequency Stability (%) |
|------------------|-----------------|---------------------|-------------------------|
| C                | 27.255          | 5                   | 0.04                    |
| A                | 460-462         | 50                  | 0.02                    |
| A                | 462-468         | 10                  | 0.02                    |
| B                | 465             | 10                  | 0.5*                    |
| A                | 468-470         | 50                  | 0.02                    |

\*including tolerance and bandwidth occupied by the emission



is 50 watts or under. Frequency modulation is generally employed.

Low power class A and class B radio transmitters are generally of the self-excited type, and care must be exercised to prevent altering any part of the circuitry which could affect the transmitter frequency. The receivers in this type of unit usually employ a superregenerative circuit which provides great sensitivity, utilizing very few tubes.

Receivers available currently for class A stations are also tunable anywhere in the band and require the proper crystals for the desired receiving frequency. A superheterodyne circuit is always used. Skill and experience are required to tune and maintain Citizens Band class A equipment properly. However, good quality equipment is not expensive to maintain, nor will it require excessive maintenance.

The operator of a Citizens Band radio communications system may employ his own radio technicians to handle maintenance if the system is large enough to make it economically feasible. Otherwise, maintenance of a radio communications system is often handled on a contract basis by independent radio service shops or by a large nationwide factory service organization like the *RCA Service Company, Inc.* This concern, for example, provides routine and 24-hour emergency service for base and mobile radio equipment in many parts of the country for a flat monthly fee which includes all labor, tubes and parts.

To service Citizens Radio class A equipment, the same type of hand tools, meters and tube testers are required as for servicing TV and radio receivers. In addition, a wiring jig to permit bench testing of mobile units plus a suitable 6- or 12-volt d.c. power supply to simulate the vehicle power source are necessary.

A high quality u.h.f. signal generator for the 460-470 mc. band is an expensive instrument but a worthwhile investment for the shop handling a large volume of work; conventional signal generators of the type used for servicing home broadcast receivers usually

suffice for intermediate frequency alignment purposes. Another useful instrument is a power output measuring device which will aid the technician in tuning transmitters for maximum efficiency.

#### Conclusion

There are bright new vistas for citizen-business men as the result of the Citizens Radio Service. This greater use of radio not only offers the radio equipment manufacturers and the radio service industry new markets, but at the same time they too can use Citizens Radio themselves to increase the efficiency of their own operations!



## CALENDAR of Coming Events

**SEPTEMBER 29-30**—Symposium on Industrial Electronics, Mellon Institute, Pittsburgh, Pa.

**SEPT. 30-OCT. 1**—Fifth Annual Meeting of the IRE Professional Group on Vehicular Communications, Rice Hotel, Houston, Texas.

**SEPT. 30-OCT. 2**—International Sight and Sound Exposition, Palmer House, Chicago, Ill.

**OCTOBER 4-6**—National Electronics Conference, Sherman Hotel, Chicago, Ill.

**OCTOBER 6-7**—IRE Professional Group on Nuclear Science Annual Conference, Sherman Hotel, Chicago, Ill.

**OCTOBER 11-15**—AIEE Fall General Meeting, Morrison Hotel, Chicago, Ill.

**OCTOBER 13-15**—Symposium on Marine Communication and Navigation, Hotel Somerset, Boston, Mass.

**OCTOBER 13-17**—Annual Convention, Audio Engineering Society, Hotel New Yorker, New York, N. Y.

**OCTOBER 14-17**—Audio Fair, Hotel New Yorker, New York, N. Y.

**OCTOBER 18-20**—Radio Fall Meeting, Hotel Syracuse, Syracuse, N. Y.

**OCTOBER 26-28**—Second National Conference on Tube Techniques, Western Union Auditorium, New York, N. Y.

**NOVEMBER 4-5**—East Coast Conference on Airborne and Navigational Electronics, Sheraton-Belvedere Hotel, Baltimore, Md.

**NOVEMBER 8-10**—Microwave Symposium, Engineering Societies Auditorium, New York, N. Y.

**NOVEMBER 10-11**—IRE-AIEE Conference on Electronic Instrumentation and Nucleonics in Medicine, Morrison Hotel, Chicago, Ill.

**NOVEMBER 18-19**—Sixth Annual Electronics Conference, sponsored by the Kansas City Section, IRE, Hotel President, Kansas City, Mo.

**NOVEMBER 18-19**—Symposium on Fluctuation Phenomena in Microwave Sources, Western Union Auditorium, New York, N. Y.

# It pays to choose crystals from the world's most complete line!

Whether your crystal requirement involves extreme miniaturization, stability, unusual frequencies, weight reduction or maximum protection against moisture, temperature changes, shock or vibration, Standard Piezo has the answer . . . fully tested and proved in the world's most critical military, aviation, commercial, and industrial services.

**STANDARD PIEZO COMPANY**  
Carlisle, Pa.

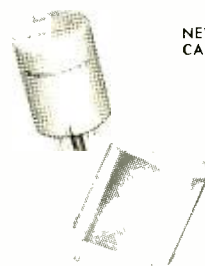

NEW 20-PAGE  
CATALOG ON  
REQUEST

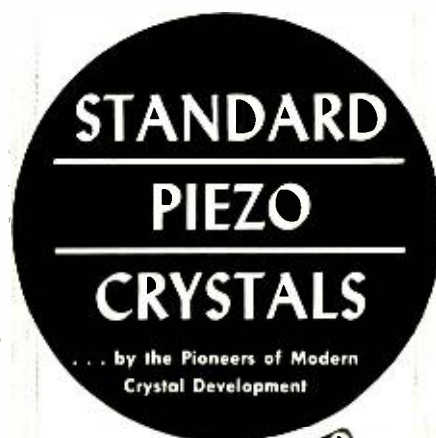

Approximate communications range for various antenna heights (460-470 mc.).

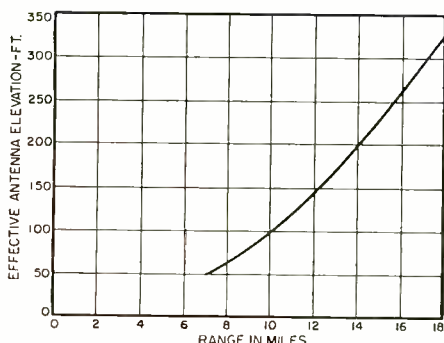

Circle No. 26 on Reader Service Card

## New Products

(Continued from page 25)

tion at 500 cps and operational shock of 50 g, and they will handle 5-ampere resistive contact loads.

The high operational and vibration characteristics of these two units, each operable in any position, are attributed to a well-balanced and compact design, four-point suspension mounting, and efficient magnetic structure which permits high tension spring values on the blade. Complete information can be obtained by writing to Harold Fox, U. S. Relay Company, 1744 Albion St., Los Angeles 31, Calif.

Circle No. 85 on Reader Service Card

## ENCAPSULATED TOROIDS

High standards of accuracy and stability have been incorporated into the new line of encapsulated toroids announced by Dietz Design and Manufac-

turing Co., Grandview, Mo. These toroids are available wound on standard or temperature-stabilized cores with permeabilities of 125, 60, 26 or 14.

The outstanding feature of the new line is a molding technique which permits: (1) relief of mounting strains for absolute physical and electrical uniformity of product, (2) guaranteed accuracies as great as 1/10 of 1% or one turn of winding where necessary, (3) hermetic sealing which meets MIL-T-27 requirements, and (4) low cost as a result of low rejection rates even at high accuracies.

Circle No. 86 on Reader Service Card

## MAGNETIC SERVO AMPLIFIER

Featuring one-cycle response, the R6G10W1 magnetic amplifier announced by Polytechnic Research & Development Co., Inc., is ideally suited for many medium-performance indicating- or position-type servomechanisms. If a simple preamplifier is added, it may be employed in the most accurate and demanding types of control systems.

The design of this servo amplifier for one-cycle response assures the widest possible bandwidth consistent with the use of 60 cps as the power supply frequency, and thus reduces many of the stabilization problems formerly encountered when incorporating magnetic amplifiers in servomechanisms.

For complete information, address inquiries to Polytechnic Research & De-

| PHOTO CREDITS |                                |
|---------------|--------------------------------|
| PAGE          | CREDIT                         |
| 7, 8, 9 (top) | .....Radio Corp. of America    |
| 9 (bottom)    | Stewart-Warner Corp.           |
| 14, 15        | .....General Electric Co.      |
| 17, 18, 19    | .....Signal Corps Engrg. Labs. |
| 20            | ....Lenkurt Electric Co., Inc. |

velopment Co., Inc., 202 Tillary St., Brooklyn 1, N. Y.

Circle No. 87 on Reader Service Card

## TV FILM CAMERA

Federal Telecommunication Laboratories, Nutley, N. J., division of International Telephone and Telegraph Corporation, has announced the addition of a newly developed camera for televising film to its line of TV broadcast equipment. Utilizing a small photoconductive camera tube, the camera (FTL-105A) features high definition and excellent contrast range as well as low initial and operating cost.

This camera consists of an extremely small camera head weighing only 7½ pounds, a control monitor, and a rack-mounted power supply. It may be used in a number of flexible operating arrangements, none of which requires a shading operator.

Circle No. 88 on Reader Service Card

**ROHN**  
**NEW No. 30**  
**HEAVY-DUTY**  
**COMMUNICATION**  
**and MICRO-WAVE**  
**TOWER**

**Proved in Construction, Design, and Operation**

Truly the finest tower of its kind. Made of heavy-duty tubular steel, electric welded throughout. In 10-ft. sections for easy erection, 18-in. triangular design. Can be used non-guyed to 66-ft.—guyed to 200-ft.

Call your Rohn representative or write, phone or wire: "Pioneer designers and manufacturers of all type towers."

**ROHN MANUFACTURING CO.**  
DEPT. REE • 111 LIMESTONE, BELLEVUE  
PEORIA, ILLINOIS • PH. 4-9156

Circle No. 3 on Reader Service Card

**SPLICES MAGNETIC TAPE**  
*Neatly - Quickly - Easily*

Kit includes plastic splicer which adheres to recorder or worktable, generous supply of pre-cut tape splicing tabs, handy blade, instructions and plastic case. Only \$1.50 postpaid. If your dealer can't supply you, order from ...

**COUSINO, INC.**  
2321 Madison Ave. Toledo 2, Ohio

Circle No. 27 on Reader Service Card

## "RATE-GROWN" JUNCTION TRANSISTOR PRODUCTION

**M**ASS PRODUCTION of low cost, exceptionally high frequency transistors is expected to get under way at the General Electric Company within the next two years. At the present time, small quantities—on the order of a few hundred a week—are being fabricated on a pilot line in Syracuse, N. Y., for engineering and military evaluation and ultimate sampling to design groups. Wide-scale sampling to the electronic industry will begin late this year.

Plans for large quantity production have been made possible through the development of a "rate-grown" method of mass-producing essential transistor elements which involves introducing special impurities, gallium and antimony, and varying the heat controls during the crystal growing process. By this method, as many as 100 wafer-thin layers of specially treated germanium are formed in a 6" ingot. The ingot is then diced into bars several thousandths of an inch long, with a layer through the center of each bar which does the work of a grid. The sections of the transistor bar on either side of this layer take the place of the cathode and plate in a tube.

When leads are attached to the transistor bars in the triode configuration, usable gain at frequencies up to 15 mc. will result. Tetrodes made from the transistor bars will give usable gain up to 150 mc. Oscillations may be ob-

tained from the triodes up to 35 mc., while oscillating frequencies up to 300 mc. are obtainable from the tetrode transistors. Electronic equipment using the new rate-grown transistors has been successfully operated at temperatures in excess of 85°C (190°F) for many hundreds of hours.

Circle No. 84 on Reader Service Card

Upper left: germanium ingot produced in two hours by the "rate-grown" method. Lower left: thousands of transistor bars sliced from the ingot. Right: magnified view of transistor construction.





## Transistor Bridge

(Continued from page 11)

To measure  $h_{21}$ , a 100,000-ohm resistor, designated as  $R_k$  in Fig. 8, is inserted in the emitter circuit. Since typical values of  $R_{11}$  are of the order of 100 ohms, the effective resistance of the emitter circuit is  $R_k$ . The partial derivative of  $v_o$  may then be replaced by  $\delta i_e R_k$ , and the quantity measured becomes:

$$\frac{1}{R_k} \frac{\delta i_e}{\delta i_o} \Big|_{v_i = 0} = \frac{1}{R_k} h_{21} \quad (12)$$

The bridge reading is in micromhos; therefore:

$$h_{21} = 0.1 \times \text{bridge reading} \quad (13)$$

To measure  $h_{21}$ , it is necessary to throw the sign of coefficient switch to negative, as before, to supply accurate in-phase test voltages.

Bridge modifications and all but one switch (the transistor switch which enables one to use the bridge for transistor measurements) are housed in a panel mount measuring approximately 15½" x 5½" x 5". Two power supplies wired into the bridge setup supply the emitter and collector bias requirements. Constant current bias is supplied to the emitter whereas a constant voltage is supplied to the collector. A switching arrangement provides for constant current to the collector when point-contact transistors are being measured. The measuring of  $h_{11}$  requires an a.c. short circuit in the collector circuit. In measuring junction transistors, this added provision is easily taken care of by a shorting strap across the audio choke in the collector circuit which is used when measuring  $R_{11}$  of a point-contact transistor.

In the test procedure outlined in Table 1, a bridge oscillator output of approximately 1000 cps at 25 volts results in a test signal level of 3.4 volts. This signal level appears in the test circuitry when the "multiply by" switch is set to 1. With the aid of an oscilloscope null detector, it is possible to observe whether or not the test signal overloads the transistor under test. Setting the "multiply by" switch to the position marked 10 results in a decrease

of the test signal level by a factor of 10 to 0.34 volt. The next larger "multiply by" switch positions result in proportionately lower test signal levels. Therefore, with the aid of the scope detector, an appropriate test signal can be chosen. Table 1 lists the "multiply by" switch positions suitable for performing the various required tests.

Measurement of the junction transistor hybrid parameters becomes a very simple and straightforward operation when the Type 561-D bridge is used. The range of the bridge, as quoted by the *General Radio Company*, enables the measurement of  $h_{11}$  values of from 50 ohms to 20 megohms,  $h_{22}$  values down to 0.05 x 10<sup>-6</sup> mhos. Values of  $h_{12}$  from 0.001 to 10,000 can be detected. The  $h_{21}$  measurement range is 0.002 to 5000. One restriction for the accurate measurement of  $h_{21}$  is that the value of  $h_{11}$  must not exceed 1000 ohms. Since a fixed resistance ( $R_k$ ) of 100,000 ohms has been used to describe the input resistance in the  $h_{21}$  test, an effective value for  $h_{11}$  of more than 1000 ohms would introduce an error of greater than 1%. As many junction transistors exhibit  $h_{11}$  values of less than 100 ohms, this is no problem. Accuracy of the bridge is  $\pm 2\%$  for the  $R_p$  test position for values of from 10<sup>3</sup> to 10<sup>6</sup> ohms. At lower and higher values, the error increases slightly. The expression  $\mu = G_m R_p$  will check to  $\pm 2\%$  when the quantities are all measured by the bridge and when  $R_p$  is between 1000 ohms and 1 megohm.

Type 561-D bridge is capable of measuring either *n-p-n* or *p-n-p* junction transistors. However, to date, data have been compiled for small signal behavior in the grounded base connection only. The instrument has enough versatility to enable the measurement of transistors in the grounded emitter or collector conditions as well.

### REFERENCES:

1. *Dorman, David, "A Bridge Transistor Tester," RADIO-ELECTRONIC ENGINEERING, February, 1954, p. 5.*
2. *Operating Instructions for Type 561-D Bridge, General Radio Company, Form 307-D.*
3. *Tuttle, W. N., "Dynamic Measurement of Electron-Tube Coefficients," Proc. I.R.E., Vol. 21, June, 1933, p. 844.*
4. *Wallace, Jr., R. L., and Ruisbeck, G., "Duality as a Guide in Transistor Circuit Design," B.S.T.J., Vol. XXX, April, 1951, p. 381.*



### INDEX OF ADVERTISERS

| NAME                                   | PAGE | NAME  | PAGE         |
|--|------|---|--------------|
| Adair Engineering Co., George P.       | 33   | Measurements Corporation                    | 25, 33       |
| Amperite Co., Inc.                     | 28   | Microdot Division, Felts Corporation        | 31           |
| Ampex Corp.                            | 23   | Monitoradio Radio Apparatus Corp.           | 34           |
| Cannon Electric Co.                    | 21   | Motorola Communications & Electronics, Inc. | Fourth Cover |
| Chicago Standard Transformer Corp.     | 4    | Par-Metal Products Corp.                    | 32           |
| Colortone Electronics, Inc.            | 27   | Printloid Inc.                              | 31           |
| Connecticut Telephone & Electric Corp. | 6    | Radio Corporation of America                | 3            |
| Cousino, Inc.                          | 38   | RCA Service Company, Inc.                   | 25           |
| Electro Motive Mfg. Co., Inc., The     | 5    | Resinite Corporation                        | 35           |
| Electro-Voice                          | 39   | Rohn Manufacturing Company                  | 38           |
| Gabriel Company, The                   | 33   | Standard Piezo Co.                          | 37           |
| Hickock Electrical Instrument Co., The | 29   | United Transformer Co.                      | Second Cover |
| Klipsch & Associates                   | 33   | Wiley & Sons, Inc., John                    | 33           |
| McIntosh, Frank H.                     | 33   | Zophar Mills, Inc.                          | 35           |

## Extra Rugged—Light Weight HIGH ARTICULATION E-V Mobile-Mikes

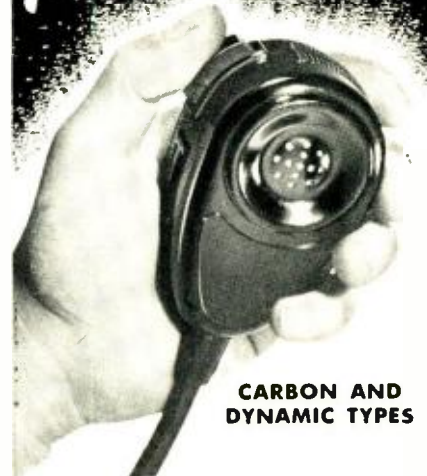

**CARBON AND DYNAMIC TYPES**

E-V Mobile-Mikes are designed for the ultimate in speech transmission! You get high intelligibility, high output, more usable power level, less listener fatigue and other E-V features. *Proved in toughest service.* Used in public safety, aircraft, railroad and government communications. High impact phenolic case. Permanent finish. Weighs as little as 7 oz. Model 210 Carbon lists at \$28.50. Model 600-D Dynamic lists at \$38.50.

### EXACT REPLACEMENT

Carbon Mobile-Mikes also available for exact replacement in current Motorola, RCA, G.E. and similar equipment. You get full advantage of E-V design and performance features.



### NOISE-CANCELLING DIFFERENTIAL\*



Close-talking, carbon type. Assures clear speech transmission under high ambient noise in any weather or climate. Blast-proof, waterproof, shock-resistant. Model 205 lists at \$38.50. Model 602 Differential Dynamic at \$49.50 list. (\*Patent No. 2,350,010)

Send for Bulletin!

# Electro-Voice

BUCHANAN, MICHIGAN

Export: 13 E. 40th St., N.Y. 16, U.S.A., Cables: Arlab

**AUTHORIZED DISTRIBUTORS EVERYWHERE**  
Circle No. 28 on Reader Service Card

6/12?

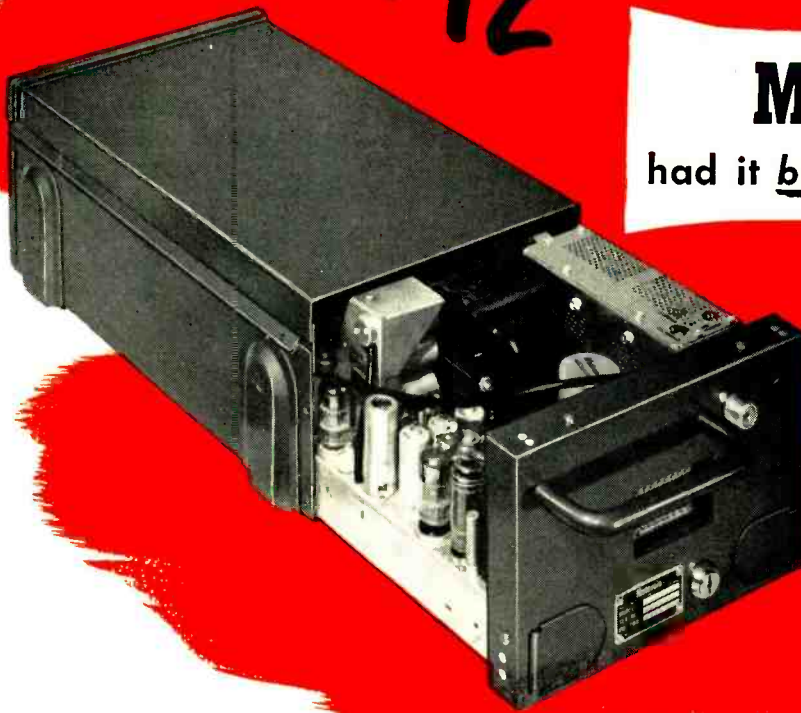

**Motorola**  
had it built-in a year ago

*A growing number of automobile manufacturers are changing from 6 to 12 volt electrical systems. Motorola 2-way radio now gives you built-in protection against expensive obsolescence should any part of your fleet be affected by this trend.*

**WHAT IT IS** — It's truly universal 6/12V equipment—2-way radio that can be interchanged in mixed 6 and 12-volt fleets without modification of power supplies, jumpers, plugs, connectors, cables or switches. When re-installing in a 12-volt car, no cable replacement is required. It is so foolproof that you can safely make changeovers in the dark without worry of burning out tubes or damaging a power supply.

**FEATURES** — The *all-vibrator* power supply attains over 70% power conversion efficiency with a resultant power drain reduction of up to 40% — for more power per unit size per ampere drain than any other sets on the market — all this, plus the superior performance of Motorola's famous Sensicon with guaranteed permanent selectivity and seven other exclusive features.

**ACCEPTANCE** — Again anticipating the trends, Motorola offers freedom from obsolescence, and superior performance at lower cost. You can easily see and hear the difference — greater signal strength, more audio power, longer battery and generator life, lower maintenance costs. You get all this in Motorola's truly universal 6/12-volt mobile units — available in the following classes:

- 25-54 mc., 25-30 and 50-60 watts R.F. output
- 144-174 mc., 10 and 25 watts R.F. output
- 450-470 mc., 18-20 watt R.F. output

Here is a partial list of Motorola customers who have 6/12 volt interchangeable mobile units—

|                       |                              |                         |
|-----------------------|------------------------------|-------------------------|
| Michigan State Police | Community Public Service Co. | Florida State Police    |
| Ohio State Police     | County of Orange, Calif.     | Iowa State Police       |
| Boston Edison Co.     | El Paso National Gas Co.     | State of South Carolina |



**Motorola Communications & Electronics, Inc.**  
A SUBSIDIARY OF MOTOROLA, INC.  
4501 W. Augusta, Chicago 51, Ill. • Rogers Majestic Electronics, Ltd., Toronto, Canada

For more information, circle No. 29 on Reader Service Card